

DOCUMENT RESUME

ED 085 553

95

CE 000 733

AUTHOR Maxim, D.; And Others
TITLE Job Demand Forecasting Program. A Vocational Education Planning System for Local School Districts. Volume VII.
INSTITUTION Government Studies & Systems, Philadelphia, Pa.; Mathematica, Inc., Bethesda, Md.
SPONS AGENCY New Jersey State Dept. of Education, Trenton. Div. of Vocational Education.
PUB DATE Jun 73
NOTE 183p.; For related documents, see CE 000 731-2, 734-5 and CE 000 785-8
EDRS PRICE MF-\$0.65 HC-\$6.58
DESCRIPTORS Algorithms; *Computer Oriented Programs; Educational Planning; Employment Opportunities; *Labor Market; Labor Supply; *Manpower Needs; *Occupational Information; *Prediction; Vocational Education
IDENTIFIERS *Labor and Industry Occupational Needs System; LIONS; New Jersey

ABSTRACT

The report, one of a series resulting from a project to design planning procedures for local and State vocational agencies, describes LIONS (Labor and Industry Occupational Needs System), a computer system designed to provide forecasts of the demand for various occupational skills by area for the State of New Jersey. The methodology may have application to similar planning and forecasting problems in other States. To enable the reader to understand and effectively utilize the LIONS system, the report is divided into six sections: an introduction and overview, a qualitative description of the methodology, input preparation and running instructions, output report contents, comments and system error messages, and appendixes containing a detailed statement of the algorithms and a summary of the input data requirements. (AG)

A Vocational Education Planning System FOR LOCAL SCHOOL DISTRICTS

NEW JERSEY STATE DEPARTMENT OF EDUCATION
DIVISION OF VOCATIONAL EDUCATION
225 WEST STATE STREET
TRENTON, N.J. 08625

U.S. DEPARTMENT OF HEALTH,
EDUCATION & WELFARE
NATIONAL INSTITUTE OF
EDUCATION
THIS DOCUMENT HAS BEEN REPRO-
DUCED EXACTLY AS RECEIVED FROM
THE PERSON OR ORGANIZATION ORIGIN-
ATING IT. POINTS OF VIEW OR OPINIONS
STATED DO NOT NECESSARILY REPRESENT
OFFICIAL NATIONAL INSTITUTE OF
EDUCATION POSITION OR POLICY

with the assistance of
GOVERNMENT STUDIES & SYSTEMS, INC.
3401 MARKET STREET
PHILA., PA. 19104

JOB DEMAND FORECASTING PROGRAM

Vol. VII



FILMED FROM BEST AVAILABLE COPY

ED 085553

WE 000733

ED 085553

A VOCATIONAL EDUCATION PLANNING SYSTEM
FOR
LOCAL SCHOOL DISTRICTS

Volume VII: Job Demand Forecasting Program

Produced For

Edison Township

Linden

Lower Camden County Regional
High School District

Middlesex County Vocational Schools

Somerset County Vocational School
and Technical Institute

and

The State Department of Education
Division of Vocational Education

With the assistance of

Government Studies & Systems, Inc.

The project presented herein was performed pursuant to a grant from the New Jersey State Department of Education, Division of Vocational Education under Public Law 90-576, Part C, Section 131, (b).

July 1970 - June 1973

Acknowledgments

The Division of Vocational Education of the New Jersey State Department of Education has long recognized the need to introduce more science into the art of educational planning. This publication is an outgrowth of its efforts to devise more systematic, objective, and precise bases for program decisions. The Division has determined, moreover, that the key to the success of its system is to insure that the Local Education Agency has an advanced planning capability.

Grateful acknowledgment is given to Dr. Robert M. Worthington, former Assistant Commissioner of Education (DVE), for initiating this study and to Mr. Stephen Poliacik, Assistant Commissioner of Education (DVE), for his guidance and support in continuing the study when problems seemed insurmountable. Also, to Former Commissioner of Education, Dr. Carl L. Marburger, and Acting Commissioner of Education, Dr. Edward W. Kilpatrick for their support and patience. Appreciation is further expressed to the Superintendents of the five LEAs: Mr. Charles A. Boyle, Edison; Mr. Americo R. Taranto, Linden; Mr. Joseph R. Wilson, Somerset; Mr. Leonard A. Westman; Lower Camden County Regional High School; and Dr. J. Henry Zanzalari, Middlesex County Vocational Schools and Technical Institute for their cooperation and understanding.

Finally, to the staff of the Division of Vocational Education, and particularly Dr. Morton Margules, Associate Director, State Division of Vocational Education (Ancillary

Services); Mr. Harold R. Seltzer, Director, Bureau of Occupational Research and Development; and Mr. Alvin Weitz, Director of Program Development for their invaluable assistance and insights. To Government Studies & Systems, Inc., Mr. Charles P. Cella, Director; Mr. Roger L. Sisson, Associate Director; Mr. Joseph H. Bosworth, Program Director; and Mr. Nelson G. Freed, Project Manager for their knowledge and technical capability so necessary in developing and testing this planning system.

Volume VII was developed by MATHEMATICA, Inc. under the direction of Government Studies & Systems, Inc. The principal MATHEMATICA contributors are D. Maxim, D. Cullen, and F. Mason. Significant technical input for the model came from Mr. Gary King, New Jersey State Department of Labor and Industry.

Series Preface

Planning is a universal concept based on the proposition that if you think a bit about what you intend to do, you are likely to do whatever it is better than if you don't think about it. This process of thinking ahead generally involves gathering information, analyzing the information and then formulating one or more courses of action to follow. The planning system presented here embodies these elements in operational procedures for planning for school districts.

The Vocational Education Planning System for Local School Districts draws heavily upon a growing body of experience in educational planning which has been generated by Government Studies & Systems (GSS). The introduction describes these concepts. Out of this experience has evolved a set of planning techniques, particularly suited by design and through actual use, to enable effective planning. The bases for and uses of indicators, planning factors, forecasts, models and others of these techniques are clearly laid out in this manual as they appear in the normal course of the planning cycle.

This manual is one of several resulting from a project to design planning procedures for local and state vocational education agencies. This manual describes the overall planning process for LEAs. It is to be used in conjunction with the following manuals:

- Volume I: Local Education Agency User's Manual
- Volume II: Local Education Agency User's Data Collection Manual
- Volume III: Local Education Agency Planning Analyst's Procedures
- Volume IV: State Application Funding Procedures
- Volume V: Enrollment Forecasting Procedures
- Volume VI: Procedures for Estimating Adult and Post-Secondary Potential Enrollment
- Volume VII: Job Demand Forecasting Program
- Volume VIII: Training Materials
- Volume IX: Guide to Project Manuals

The most important ingredients in effective planning, however, are the people who do the planning. The planning team itself should include, at the very least, those who are going to be directly responsible for the execution of the plan, once developed, and those who are otherwise directly affected by the plan. People who participate in the planning process, who see their input take shape in a plan, tend to be better advocates and implementors of that plan.

TABLE OF CONTENTS

Page

Acknowledgments.....	i
Series Preface.....	iii
A. INTRODUCTION AND OVERVIEW.....	A1-A8
B. A QUALITATIVE DESCRIPTION OF THE METHODOLOGY.....	B1-B7
C. INPUT PREPARATION AND RUNNING INSTRUCTIONS.....	C1-C57
D. OUTPUT REPORT CONTENTS.....	D1-D36
E. COMMENTS AND SYSTEM ERROR MESSAGES.....	E1-E20
F. APPENDICES	
APPENDIX F1	
DETAILED STATEMENT OF THE ALGORITHM.....	F1.1-F1.28
APPENDIX F2	
SUMMARY OF INPUT DATA REQUIREMENTS.....	F2.1-F2.14
APPENDIX F3	
STANDARD AND SPECIAL INDUSTRY CODE STRUCTURES.....	F3.1-F3.3

A INTRODUCTION AND OVERVIEW

What is LIONS?

LIONS, an acronym for Labor and Industry Occupational Needs System, is a computer system designed to provide forecasts of the demand for various occupational skills by area (county, LMA, state, etc.) for the State of New Jersey.

The need for LIONS arose from the planning process currently being conducted by the State Department of Vocational Education. In order to intelligently plan the size, extent and regional structure of vocational education programs and facilities it is, of course, necessary to have an estimate of the demand by skill by region. Until LIONS, no such systematic forecast or methodology existed.

The methodology which underlies LIONS was developed principally by Mr. Gary King of the State Department of Labor and Industry. Novel in many respects, this methodology may have application to similar planning and forecasting problems in other states. For this reason the federal government has expressed interest in its application.

The computer implementation and programming of LIONS has been conducted by MATHEMATICA, working with Government Studies and Systems. Though simple in concept, the methodology is quite complex in practice due to the fact that there is little commonality between relevant inputs, and difficulties, as well, with the consistency of various data sources when commonality is assured. The size of the forecasting

problem is also worthy of note: forecasts for up to 199 occupational categories in 27 geographical areas together with desired aggregations of these estimates. For these reasons, a computer based methodology is essential to produce accurate forecasts within a reasonable time frame.

What is the content of this report?

This report provides documentation for LIONS to enable the reader to understand the concepts and methodology which underlie LIONS and to be able to effectively utilize the system. This report is divided into six sections. A brief description of each is shown below:

Section A, introduction and overview, provides the background and motivation for the creation of LIONS together with a guide to the balance of the report.

Section B, a qualitative description of the methodology, expands upon the brief description of LIONS provided in Section A to illustrate the major computational steps and assumptions in LIONS. Though each step described in Section B is quite straightforward, the number of steps and interactions between steps is sufficiently large to place substantial demands upon the diligence of the reader.

Section C, input preparation and running instructions, shows the required input data (format and sequence order) and a flow chart to facilitate an understanding of how the system runs.

Section D, output report contents, provides a description together with a photoreduced sample of each of the output reports which the system produces.

Section E, comments and system error messages, provides a complete description of the system checks and aborts which are designed to facilitate correct system operation.

Section F, appendices, contains a detailed statement of the algorithms and a summary of the input data requirements.

What does LIONS do?

In this section we provide a simplified discussion of various computational tasks which LIONS performs. The final output of the LIONS system is the projected annual average openings in (a maximum of) 100 occupational categories in up to 27 geographical areas (including counties, LMA's, etc.). The initial forecast date is 1975. Openings in various occupations come about from two sources:

- (i) industrial growth, and
- (ii) attrition of existing workforce.

Thus the methodology forecasts each of (i) and (ii) to produce the total.

To understand the computational processes imbedded within LIONS, it is first necessary to understand the basic inputs to the system. We will discuss these briefly and show how these imply a solution methodology.

At present the Department of Labor and Industry produces a series of employment demand forecasts termed the Current Employment Statistics. These projections are, however, not by occupation but rather by industry. Thus, to use this forecast it is necessary to know the required mix of occupations to support an industry. For example, the CES data might indicate a forecast of 12,000 personnel to be employed by the mining industry in 1975. If we knew that 35% of mining industry personnel were in the occupational category "professional," 25% in the category "managers," and the balance "clerical," we could then compute the totals by occupation for each industry, and by summing over all industries obtain the total employment by occupation.

In fact, such data (industry-occupation) does exist, but only on a national level. This data is termed the National BLS Industrial-Occupation Matrix and is available for 1960 and projected to 1975. Unfortunately, economists at the State Department of Labor and Industry have reason to believe that the industry-occupation mix for New Jersey differs substantially from that for the nation as a whole, and so it would be inaccurate to perform the calculation implied above using national data directly. Moreover, New Jersey has not developed a "New Jersey Matrix." Because of this, a more elaborate forecasting procedure is necessary.

The basic conceptual assumption which underlies this more sophisticated forecasting methodology is this:

"While the National BLS Industrial-Occupation Matrix does not apply directly to New Jersey, the trends in

New Jersey occupational employment will parallel the nation as a whole."

Given this assumption, it is possible to develop an indirect forecasting scheme which operates as follows:

"Multiply the forecast CES data for 1975 by the National Matrix to obtain 'proxy' occupation-area data for 1975. Repeat the procedure using 1960 data and divide 'proxy' 1960 data into 'proxy' 1975 data to develop a 'change factor' or estimated ratio of occupational employment 1975 relative to 1960."

Multiplying these change factors (so defined) by actual 1960 occupational employment by area will produce a forecast 1975 occupational data. The most reliable estimates of 1960 occupational employment are those provided by the 1960 Census Bureau survey.

Figure A-1 shows a schematic overview of this process. We have explained the steps A, B, C, D, E, F, G, H and I. Steps K and L convert the 1975 forecast to an average annual number of openings due to growth, while steps M and N use attrition data to calculate the average annual openings due to death and retirement. This constitutes the methodology in a nutshell.

The details of the methodology are considerably more complex. Reasons for this added complexity are twofold:

- (i) Data from different sources (e.g. CES vs. Census Bureau) are not based upon the same assumptions; and

FIGURE A-1

MODEL DESCRIPTION: COMPUTATION PHASE OF LIONS

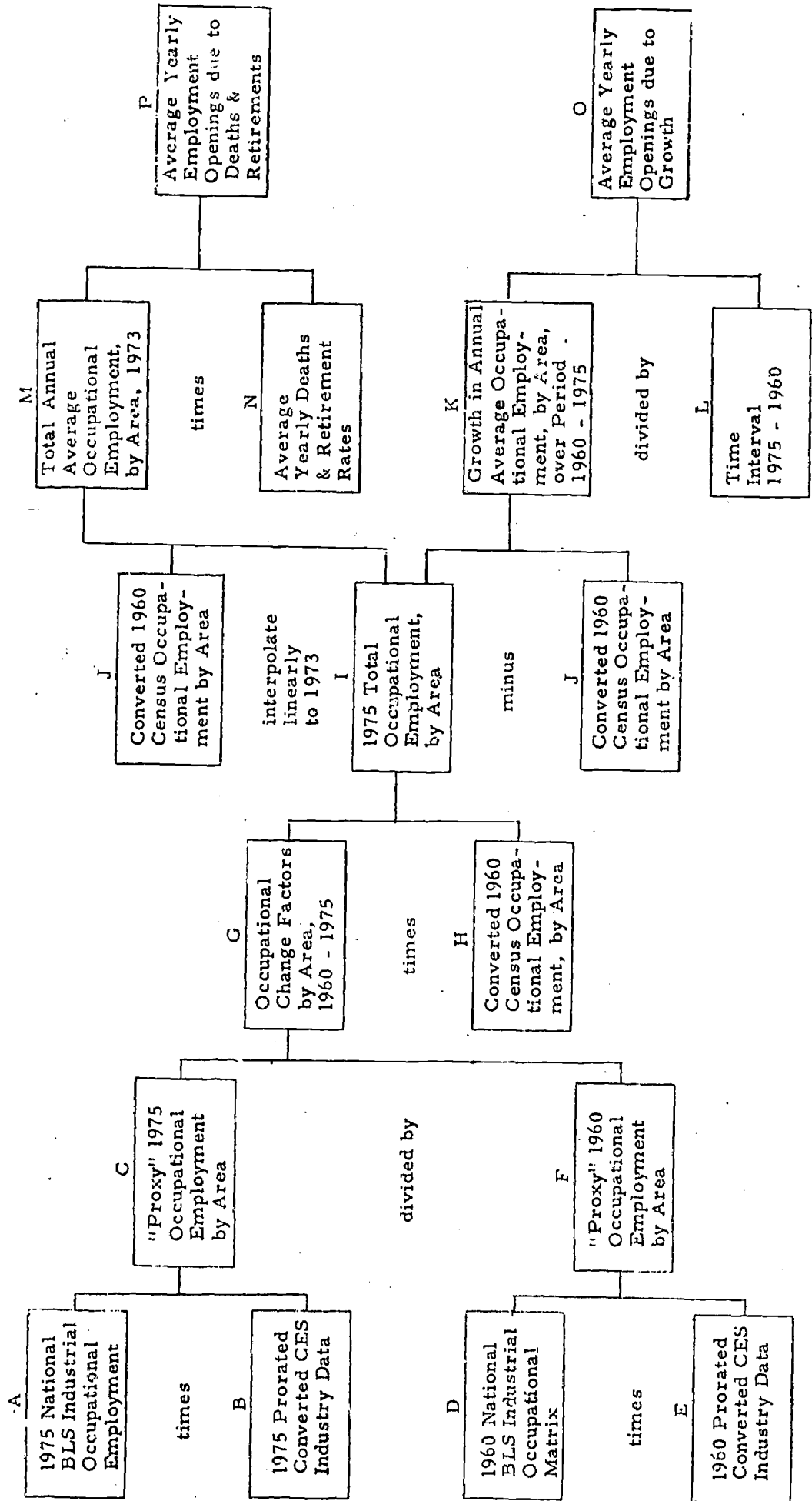

- (ii) Data from different sources are not necessarily internally consistent.

These facts necessitate a series of "filtering" operations to assure consistency and commonality. Two examples will serve to illustrate this:

- (i) CES data as forecast at the highest level of detail (e.g. all occupations for each county) does not aggregate to independent estimates of state totals. Thus it is necessary to prorate this data to ensure consistency.
- (ii) CES projections are based upon a data base of wage and salary employment by place of employment on an annual average basis. By contrast, national data is based upon total employment by place of residence on 1 April. Thus a series of conversion factors need to be employed to assure commonality between these different data sources.

Thus substantial data editing and data conversion processes are incorporated into LIONS. Figure A-2 shows a schematic flow chart which illustrates these additional steps. Each of these steps produces intermediate results which are of interest to the Department of Labor and Industry and Vocational Education.

For a more detailed qualitative description of the model turn to Section B; for a detailed step by step quantitative description of the methodology please refer to the appendices.

FIGURE A-2

FUNCTIONAL FLOWCHART FOR LIONS SOLUTION METHODOLOGY

I. DATA EDITING

Edit input data as necessary to ensure:

- (1) numerical consistency within each data set
- (2) structural consistency between data sets



II. DATA CONVERSION

Convert employment figures in edited data sets, as necessary, as shown below:

<u>From</u>	<u>To</u>
Residence	Establishment
April 1	Annual Average
Wage & Salary	Total Employment



III. COMPUTATION

Compute the following quantities:

- (1) occupational change factors, 1960 - 1975
- (2) projected annual average total occupational-area employment demand, 1975, and annual openings due to growth for the period 1960 - 1975
- (3) projected average annual openings due to deaths and retirements

B. A QUALITATIVE DESCRIPTION OF THE METHODOLOGY

In this section we provide the reader with a qualitative description of the methodology which is incorporated within LIONS. Two flow charts appear on fold-out pages at the end of this section. The second of these is the same as that displayed in section A and is reproduced here to facilitate its use with the text of the section. The first shows preliminary steps needed to generate one of the data sets used on the second. Together, they depict the computational steps which comprise the algorithm.

The flow charts are keyed to the explanatory text by means of capital letters on the chart which identify each data array, e. g., array A is the 1975 National BLS Industrial Occupational Employment array. The reader will find it helpful to refer to the flow charts while reading this section.

We shall first describe the editing operations which are necessary to provide the data arrays which are input to the computations described on the flow chart. Next we shall provide a brief description of each step in the computational phase. (Note: a detailed description of the methodology appears in appendix F-I.)

We shall first consider those data transformations which are shown on the first chart and which are performed in order to obtain converted 1960 census occupational employment data organized by establishment, i. e., place of employment, and aggregated for an average year (array H on the second chart).

- The March 1960 CES Industry Data which is for wage and salaried workers only (array Q), and is organized by establishment, is

averaged with the April 1960 CES Industry Data (array R), to arrive at an average CES Industry Data array for April 1, 1960 (array S).

- The 1960 CES annual average Industry Data (a twelve month average - array T) is then divided by the average CES Industry Data array which we just calculated. This gives us a data array which shows the ratio of annual to April 1 total statistics (array U).

- Using data which describes total commutation into an area, by industry, in conjunction with data which describes total commutation out of an area, by industry, we compute net commutation figures by area by industry (array V).

- These net commutation figures by industry by area are combined with 1960 census industrial employment data for April 1 (array W), which is organized by place of residence, to produce semi converted 1960 census industrial employment data for April 1, which is organized by place of employment rather than residence (array X).

- This matrix of semi converted April 1, 1960 census industrial employment data is multiplied by the previously calculated employment ratio of annual average to April 1, to arrive at converted, annual average 1960 census industrial employment data which is organized by place of employment (array Y).

- Analogous to the industry by area commutation matrices, we have two matrices which contain respectively, commutation into and commutation out of, areas by occupation. These matrices are combined to yield net commutation figures by occupation by area (array VV).

- These net commutation figures by occupational areas are

combined with 1960 census occupational employment data for April 1 (array WW), which is organized by place of residence, to produce semi converted 1960 census occupational employment data for April 1 which is organized by place of employment rather than residence (array XX).

- The converted 1960 census industrial employment data is used as a proration guide for the semi converted 1960 census occupational employment data to produce converted 1960 census annual average occupational employment data which is organized by place of employment (array H).

We shall now consider those data operations which are performed to obtain 1975/1960 occupational change factors by area (array G).

- Projections of 1975 national and salaries ratios of total employment to wages, by industry are divided by actual 1960 national salaries ratios of total employment to wages and by industry, to produce 1975/1960 trend factors for national ratios of total employment to wages and salaries.

- The converted 1960 census annual average industrial employment data which is organized by place of employment is divided by the 1960 CES annual averages wage and salary industrial data to produce 1960 New Jersey ratios of total employment to wage and salary by industry by area.

- These ratios multiply the 1960 CES annual average industry wage and salary data to produce converted 1960 annual average CES industry employment data, organized by place of employment (array E).

- This matrix, in turn, multiplies the 1960 national BLS industry-occupation matrix (array D) to produce a "proxy" 1960 occupational employment, by area, matrix (array F).

- The 1960 New Jersey ratios of total employment to wages and salaries by industry by area, are combined with the 1975/1960 trend factors for these ratios, to produce 1975 New Jersey ratios of total employment to wages and salaries.

- These 1975 ratios then multiply projected 1975 annual averages CES industry wage and salary data, to produce converted 1975 annual average CEW industrial employment data, by place of employment (array B).

- This matrix is then multiplied by a projected 1975 national BLS industry-occupation matrix (array A) to produce a "proxy" 1975 occupational employment matrix (array C).

- Finally, the 1960 "proxy" occupational employment matrix (array F) is divided into its projected 1975 counterpart (array C) to obtain 1975/1960 occupational change factors by area (array G).

The next series of data operations has as its goal the development of a matrix of total average yearly incremental occupational employment by area.

- The 1975/1960 occupational change factors, just computed (array G), multiplied by the converted 1960 census occupational employment data (array H), yields projected 1975 total occupational employment, by area, by place of employment (array I).

- This projected 1975 total occupational employment matrix, averaged with its 1960 counterpart (array J), is used to develop an average yearly incremental occupational employment by area matrix (array O). This matrix indicates change due to industrial growth.

- A linear interpolation of the two matrices used in the previous step, provides an estimate of 1975 total occupational employment, by

area (array M).

- This matrix, multiplied by 1960 national death and retirement rates, by occupation (array N), produces estimates, of the average yearly incremental employment openings, by occupation, due to death and retirement (array P).

- Adding the matrices of openings due to industry growth (array O) and deaths and retirement (array P), we arrive at total average yearly incremental occupational employment openings, by area.

FIGURE B-1
PRELIMINARY CALCULATIONS

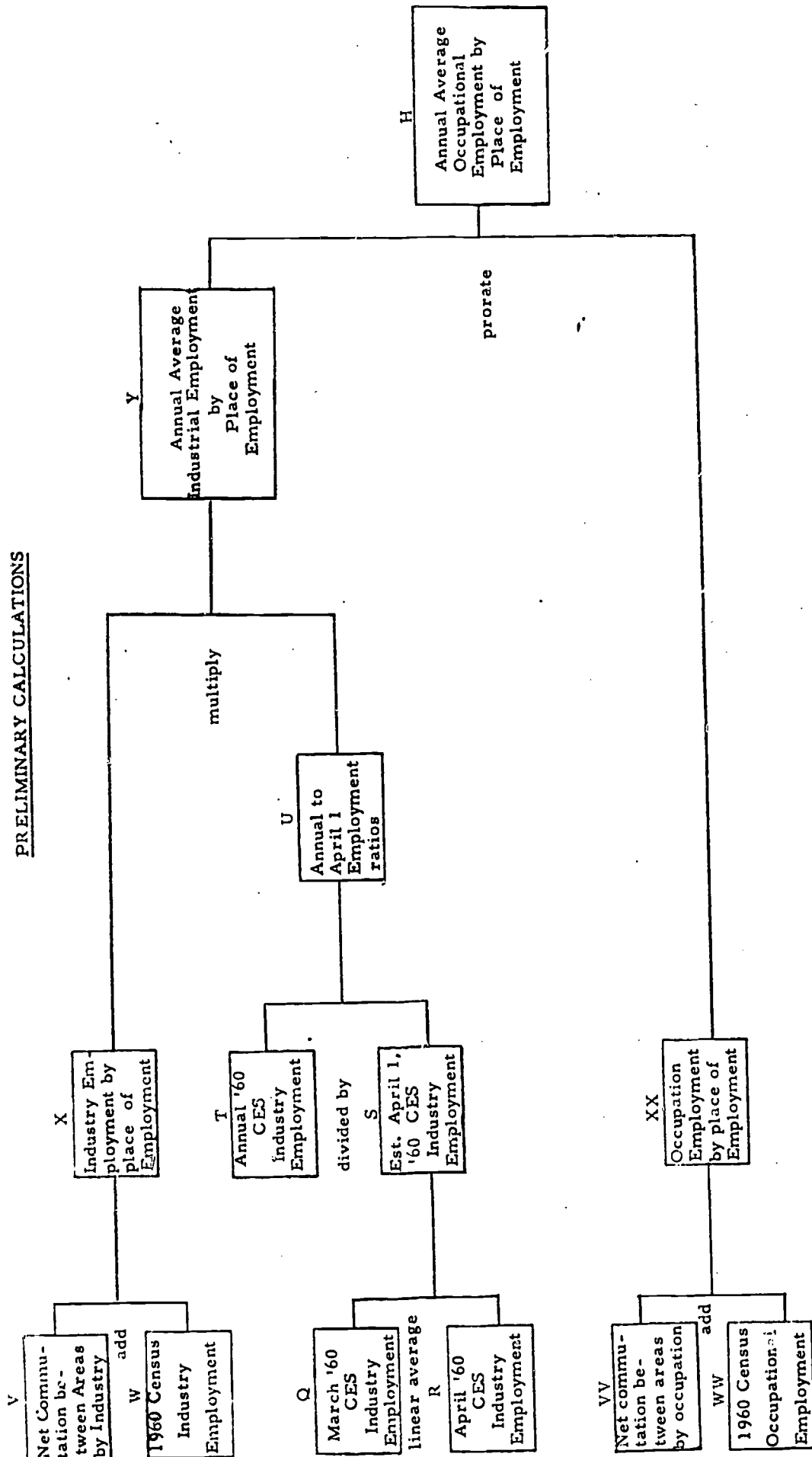
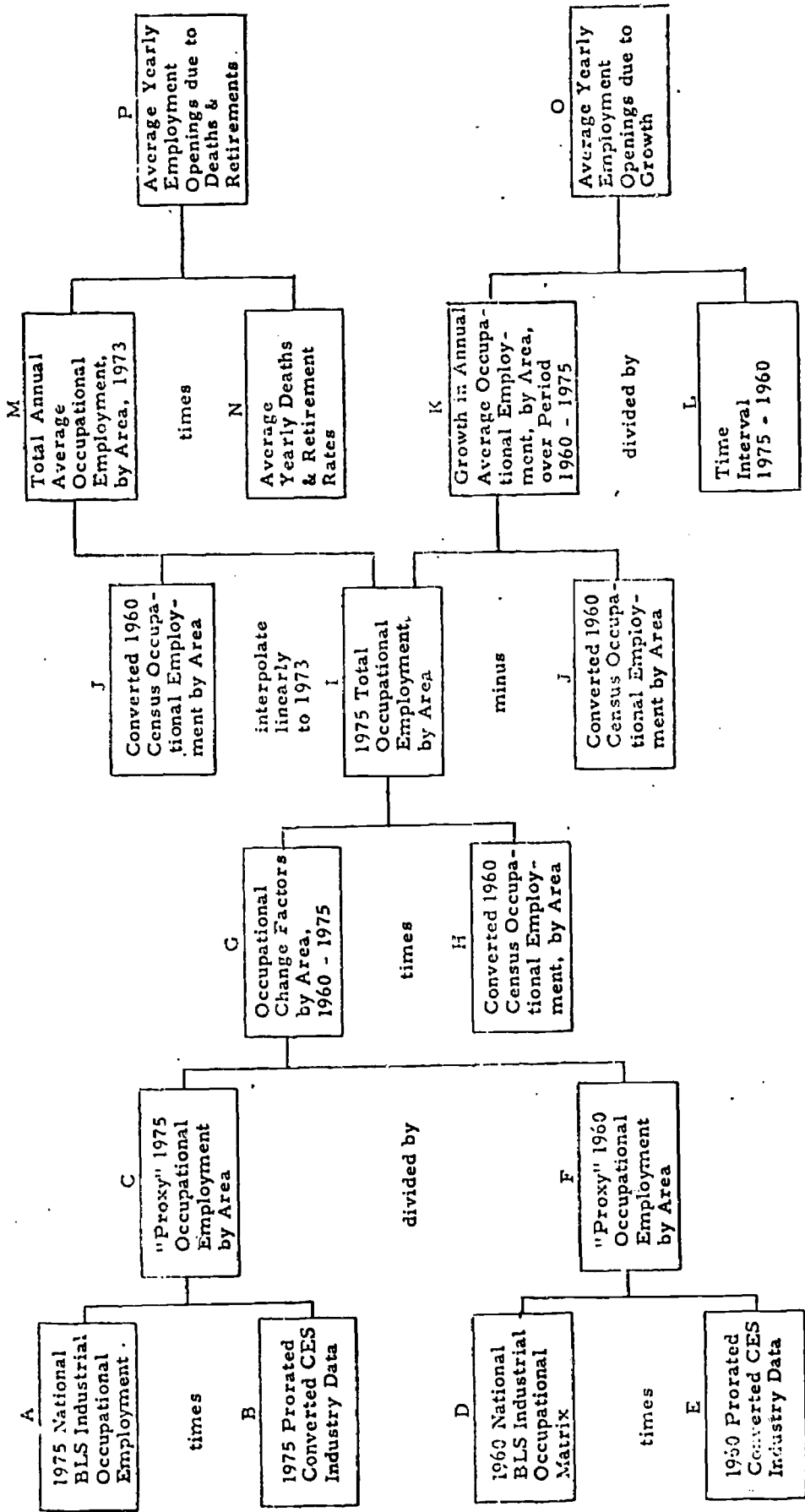

FIGURE B-2

MODEL DESCRIPTION: COMPUTATION PHASE OF LIONS



C. INPUT PREPARATION AND RUNNING INSTRUCTIONS

This section will be of primary interest to those persons responsible for preparing LIONS input files and conducting runs of the system. Those readers concerned with the computational aspects of LIONS, or the output reports which are produced by the system, are advised to skip this section.

We shall first describe the abbreviations that are used to specify formats for data elements. Next we shall describe, and provide examples of all of the data required by LIONS. The data formats will be presented in order of use (i. e., data required for algorithm A, algorithm B, etc.). For further description of the data sets themselves (i. e., their content, not format) the reader is referred to appendix F-II. For ease of reference, we have included the appropriate F-II codes for each data set.

Finally, this section contains instructions on setting up the component jobs for running on the computer.

Input Format Descriptions

Data elements are entered into the LIONS package, on cards, in one of three formats; alphanumeric (A format), integer (I format), or floating (F format). In this section we shall describe the general characteristics of these formats.

A Format

The alphanumeric format is used to enter names, identifiers, and descriptions. The general form for A formats is A_n , where n is the number of card columns allocated to the data element. An alphanumeric descriptor may consist of any combination of alphanumeric, numeric, or special characters. For consistency, all such names should be left adjusted, that is, the three character descriptor ABC, if entered in a field of A_5 , should be entered as ABC--(-denotes a blank), not as --ABC.

I Format

The integer format is used to enter whole (or integral) numbers. The general form for I formats is I_n , where n is the number of card columns allocated to the data element. Integer numbers are entered right adjusted in their field. (e.g., the integer 12, when entered in a field of I_5 , should be ---12 (-denotes a blank), 12--- would be interpreted by the computer as 12000). The only valid characters in an integer field are the ten characters 0, 1, 2, 3, 4, 5, 6, 7, 8, 9, and the character blank. No decimal

point may appear in an integer field.

F Format

Floating format is used to enter numbers which may be other than integers. The general form for F formats is FW.X, where W is the number of card columns allocated to the data element, and X is the number of positions which are implicitly assumed to follow the decimal point. Example: If the numbers 12345 appeared in a field with format F5.2, the data element would be interpreted as 123.45. If the same numbers appeared in a field in the format F5.4, the element would be interpreted as 1.2345.

In order to avoid confusion that might arise in the proper positioning of floating numbers, it is suggested that the override option be employed for such numbers. This option allows the user to explicitly enter a floating number with a decimal point. In such cases the X in FW.X is ignored.

Example: If the sequence 12.34 appeared in a field with format F5.X, where X is any integer 0,1..5, the data element would be interpreted as 12.34.

Note: When entering a number with a decimal point, the decimal point is counted as one position in the field. That is, 12.345 would not fit in an F5.X field.

Input Data Sets - Algorithm A

There are four data sets required for algorithm A. Sets one and three (see following page) are portions of the special industry code structure. The formats for industry and occupation structures fully described in the section on inputs for code structures following this discussion of inputs for the algorithms.

Data set 2 is part of the April 1, 1960 census industrial employment matrix. For each of fourteen areas, there is a set of data items for each industry code. In the sample data set (following the data set descriptions) we display a portion of this data set. Specifically, for area 0, we show data for industry codes 000000 to 300000 and codes 909190 to 909300 as well as the 0 record which indicates the end of the area's data. We similarly display portions of area 29 (the second area) and area 12 (the last area).

Data set 4 of algorithm A is also part of the April 1, 1960 census industrial employment matrix. For each of ten areas, there is a set of data for varying codes. We display all of the data for area 5 (the first area) and area 18 (the last area).

NOTE: Printouts of area codes will have "leading zeros" printed as blanks. For example, code 003000 will print as bb3000, where b indicates a blank.

INPUT DATA SETS - ALGORITHM A

1. Special Industry Code Structure (XV:B)

Maximum code index: 167

(cf: Input for Code Structures)

2. April 1st 1960 Census Industrial Employment

For each area: 0, 29, 30, 9, 11, 1, 13, 7, 14, 20, 2,
16, 4, and 12 (in this order):

For each code in the special industry code structure
for which data is available - 1 card containing:

Columns	5-10	11-20	21-30	31-40
Format	I6	I10	I10	I10
Location	IA	INDEX	IB	IC
Contents	Industry Code	Index for Code	Male Employment	Female Employment

At the end of the employment data for each area:

1 card containing 0 in columns 11-20.

3. Special Industry Code Structure (XV:B) to level IVS plus codes

010100, 010800, and 101900.

4. April 1st 1960 Census Industrial Employment

For each area: 5,6, 10, 15, 17, 19, 21, 3, 8, and 18 (in this order):

For each code in the special industry code structure for
which data is available - 1 card containing:

Columns	5-10	11-20	21-30
Format	I6	I10	I10
Location	IA	INDEX	IB
Contents	Industry Code	Index for Code	Total Employment

I 1		1	582652	762844
I 1	1111	161	0	0
I 1	999	167	67707	42259
I 1	1000	3	29740	4507
I 1	1010	4	28569	4422
I 1	10800	5	191	24
I 1	10900	6	1020	61
I 1	100000	7	3223	321
I 1	101000	8	820	85
I 1	101100	9	143	19
I 1	101300	10	328	60
I 1	101400	11	1932	157
I 1	200000	12	125220	4577
I 1	300000	13	605298	240282

I 1	909200	145	7805	5186
I 1	909300	148	30917	8990
I 1		0		

END OF INDUSTRY EMPLOYMENT FOR STATE

I 2		1	450334	228190
I 2	1111	161	0	0

I 2	90920	145	1250	613
I 2	909300	148	10364	2523
I 2		0		

END OF INDUSTRY EMPLOYMENT FOR NEWARK

I 3		1	110481	49198
I 3	1111	161	0	0

I 3	909200	145	452	174
I 3	909300	148	1663	492
I 3		0		

END OF INDUSTRY EMPLOYMENT FOR MURKIN

115 079999	167	1122
115 010000	3	591
115 010100	4	357
115 010800	5	0
115 010900	6	234
115 100000	7	46
115 200000	12	1865
115 300000	13	1921
115 310000	14	772
115 320000	44	1149
115 400000	78	1304
115 500000	101	3182
115 600000	127	789
115 700000	132	3287
115 900000	110	952
115 0	0	

END OF INDUSTRY EMPLOYMENT FOR CAPE MAZ

124 009999	167	1652
124 010000	3	1282
124 010100	4	1278
124 010800	5	0
124 010900	6	4
124 100000	7	210
124 200000	12	3291
124 300000	13	23747
124 310000	14	13706
124 320000	44	10041
124 400000	78	3024
124 500000	101	7964
124 600000	127	2288
124 700000	132	10976
124 900000	110	2016
124 0	0	

END OF INDUSTRY EMPLOYMENT FOR SOMERSET

Input Data Sets - Algorithm B

There are three input data sets for algorithm B. Data set three is part of the major standard industry code structure, which is described later in the section on input for code structures.

Data set one is the April 1, 1960 census industrial employment commutation matrix. For every area - area pair (areas range from 01 to 26) the total commutation and the fraction in each of 11 code areas is required. We display all commutation out of area one (i. e., 01-01 to 01-26), and portions of the commutation out of areas 2 and 26 (the last area).

Data set two contains control figures for the commutation matrix. We display all five lines of this data set.

INPUT DATA SETS - ALGORITHM B

1. April 1st 1960 Census Industrial Employment Commutation (X:A)

For each from-area 1-26 except 22

For each to-area 1-26 except 22

1 card containing:

Column	2	4-5	7-8	12-19	20-24	25-29	30-34	35-39	40-44
Format	A1	I2	I2	I8	F5.3	F5.3	F5.3	F5.3	F5.3
Location	IA	IB	IC	ID	ACC(3)	ACC(4)	ACC(5)	ACC(6)	ACC(7)
Contents	industrial identifier "I"	from- area code	to- area code	total com- muting	fraction in 001111	fraction in 200000	fraction in 300000	fraction in 400000	fraction in 500000

	45-49	50-54	55-59	60-64	65-69	70-74
	F5.3	F5.3	F5.3	F5.3	F5.3	F5.3
	ACC(8)	ACC(10)	ACC(11)	ACC(12)	ACC(13)	ACC(9)
	fraction in 600000	fraction in 710000	fraction in 720000	fraction in 730000	fraction in 740000	fraction in 900000

2. April 1st 1960 Census Industrial Employment Commutation

Control Figures (XI:A)

For each area in II-G: 29, 30, 9, 11, 33

1 card containing:

Column	1-2	4-5	8-14	15-20	21-26	27-32	33-38	39-44	45-50
Format	A2	I2	I7	I6	I6	I6	I6	I6	I6
Location	IA	IC	ACC(2)	ACC(3)	ACC(4)	ACC(5)	ACC(6)	ACC(7)	ACC(8)
Contents	identifier "CA"	area code	000000	001111	200000	e m p l o y m e n t i n 300000	400000	500000	600000

51-56	57-62	63-68	69-74	75-80
I6	I6	I6	I6	I6
ACC(10)	ACC(11)	ACC(12)	ACC(13)	ACC(9)
710000	e m p l o y m e n t i n 720000	730000	740000	900000

3. Major Standard Industry Code Structure (XV:A)

Maximum code index: 167

(cf: Input for Code Structures)

```

// EXEC
1 01 01 00051703
1 01 02
1 01 03 00000532 0018 0084 0555 0064 0113 0013 0016 0020 0006 0066 0047
1 01 04 00001705 0018 0084 0555 0064 0113 0013 0016 0020 0006 0066 0047
1 01 05 00001003 0018 0084 0555 0064 0113 0013 0016 0020 0006 0066 0047
1 01 06 00002250 0018 0084 0555 0064 0113 0013 0016 0020 0006 0066 0047
1 01 07
1 01 08 00000302 0018 0084 0555 0064 0113 0013 0016 0020 0006 0066 0047
1 01 09
1 01 10
1 01 11 00000132 0004 0272 0284 0070 0108 0020 0035 0014 0004 0092 0007
1 01 12
1 01 13
1 01 14
1 01 15 00000234 0018 0084 0555 0064 0113 0013 0016 0020 0006 0066 0047
1 01 16
1 01 17 00000152 0023 0202 0397 0120 0107 0010 0015 0008 0009 0085 0024
1 01 18
1 01 19
1 01 20
1 01 21
1 01 23 00001701 0012 0097 0366 0124 0131 0037 0032 0019 0018 0094 0070
1 01 24 00000178 0008 0051 0310 0141 0141 0133 0062 0016 0015 0094 0029
1 01 25 00000044 0023 0202 0397 0120 0107 0010 0015 0008 0009 0085 0024
1 01 26 00000139 0008 0051 0310 0141 0141 0133 0062 0016 0015 0094 0024

1 02 01
1 02 02 00162878
1 02 03 00000053 0017 0143 0386 0103 0102 0020 0028 0019 0017 0101 0064
:
:
1 02 26 00002517 0014 0077 0410 0134 0141 0064 0036 0013 0013 0074 0034
:
:
:
:
1 26 01
1 26 02 00001080 0005 0085 0519 0099 0177 0013 0028 0011 0004 0042 0016
1 26 03 00000710 0017 0143 0386 0103 0102 0020 0028 0019 0017 0101 0064
:
:
1 26 26

```

Input Data Sets - Algorithm C

Algorithm C contains six data sets. Data set one is the major standard industry code structure, described elsewhere.

Data set 2 is the March 1960 CES industry employment matrix. There are two parts to this data set. Part one contains data for areas 8, 10, 4, 12, 5, 9, 11, 13, 14, 15, 16 and part two contains data for areas 1, 6, 2, 3, 7. We display, for both parts, employment for industry codes 000000 to 312400 and 909190 to 909300, as well as the 0 termination for each set.

Data set 3 is the April 1960 CES industry employment matrix, which is in the same format as data set 2, and is therefore not shown.

Data set 4, which is the annual 1960 CES industry employment matrix, also has the same format as data set 2, and is not shown.

Similarly, data set 6, which is the projected 1975 CES industry employment matrix, is not shown since it is also in the same format.

Data set 5 contains 1960 and 1975 ratios of total employment to wage and salary employment by industry. We display data for industry codes 000000 to 312400 and 900000 to 909190, as well as the 0 terminator.

CA 29	686072	4670	33313265535	47256122808	44435	26649	34615	4131	74796	2787	
CA 36	394083	3076	24328170055	22710	76451	13129	11473	17112	2951	40375	1291
CA 09	254415	280	870113361	35310	40070	7967	5295	8808	991	21969	12270
CA 11	119429	1637	643040102	6548	18629	4206	4194	5604	596	13831	10252
CA 33	708597	29107	54189254531	41829127739	24329	13268	41155	5248	77409	39773	

INPUT DATA SETS - ALGORITHM C

1. Major Standard Industry Code Structure (XV:A)

Maximum code index: 156

(cf: Input for Code Structure)

2. March 1960 CES Industry Employment (VI)

For each code in the standard industry code structures for which data is available

1 card containing:

Columns	3-8	10-12	15-20	21-26	27-32	33-38	39-44	45-50	
Format	I6	I3	I6	I6	I6	I6	I6	I6	
Location	IA	INDEX	IB(1)	IB(2)	IB(3)	IB(4)	IB(5)	IB(6)	
Contents	Industry Code	Index for Code		e m p l o y m e n t		for area			
			8	10	4	12	5	9	

	51-55	56-60	61-66	67-72	73-78
	I6	I6	I6	I6	I6
	IB(7)	IB(8)	IB(9)	IB(10)	IB(11)
		e m p l o y m e n t			
	11	13	14	15	16

Ending with 1 card containing a 0 in columns 10-12

Then for each code in the standard industry code structure for which data is available

1 card containing

Columns	3-8	10-12	14-20	21-27	28-34	35-41	42-48
Format	I6	I3	I7	I7	I7	I7	I7
Location	IA	INDEX	IC(1)	IC(2)	IC(3)	IC(4)	IC(5)
Contents	Industry code	Index for code		e m p	l o y	m e n t	
			1	6	2	3	7

Ending with 1 card containing a 0 in columns 10-12

3. April 1960 CES Industry Employment (VII)

Using the same format as in data set 2.

4. Annual 1960 CES Industry Employment (VIII)

Using the same format as in data set 2

5. National Ratios of Total Employment to Wage & Salary

Employment by Industry (XII)

For each code in the standard industry code structure for which data is available: 1 card containing

Columns	2-10	11-20	21-30	31-40
Format	I9	I10	F10.0	F10.0
Location	IA	INDEX	FA	FB
Contents	Industry Code	Index for Code	Ratio for 1960	Ratio for 1975

Ending with 1 card containing a 0 in columns 11-20

6. Projected Annual 1975 CES Industry Employment (IX)

Using the same format as in data set 2

A	0	1	47059	11061	38657	260620	150621	10894	80364	23057	20622	12024	2252
A	10000	3	2000	700	2800	100	2000	1400	4700	2100	2000	2750	2100
A	10100	4	1900	600	2700	100	2000	1400	4700	1900	2000	2750	2100
A	10800	5	1			1		1	1				
A	10900	6	100	100	100	1		1	1	200	1	1	
A	100000	7	150	150	700	1	100	100	200	200		270	150
A	101000	8	1			1		1	1				
A	101100	9	1			1		1	1				
A	101300	10	1			1		1	1				
A	101400	11	150			1		100	200				
A	200000	12	3300	1250	1200	5000	750	5300	4700	2300	450	600	75
A	300000	13	7600	1600	19050	121400	4600	38793	16850	3000	10900	2900	11900
A	310000	14	1750	550	10650	62200	2000	23823	8600	850	2600	1070	7250
A	312400	15	225			1300		99	100				

A	909190	139	1096			2326		800	8489
A	909200	145	493			600		9601	1584
A	909300	148	2567			14800		3367	2375
A	-1	0							

A	0	1	2059737	192230	673605	366704	184014
A	10000	3	0038100	005600	003100	003000	003100
A	10100	4	0037500	005600	003100	003000	003100
A	10800	5	0000001	000001	000001	000001	000001
A	10900	6	0000600	000001	000001	000001	000001
A	100000	7	0003264	000200	000876	000416	000700
A	101000	8	0000552	000001	000453	000001	000001
A	101100	9	0000001	000001	000001	000001	000001
A	101300	10	0000001	000001	000001	000001	000001
A	101400	11	0002711	000200	000423	000415	000700
A	200000	12	0083366	009200	024600	017500	007700
A	300000	13	0811056	077800	245858	161200	088800
A	310000	14	0437329	048100	140146	081529	045886
A	312400	15	0005700	000600	001552	000471	000426

A	909190	139	0037524	004545	011321	000337	005900
A	909200	145	0027426	002260	004744	001500	002588
A	909300	148	0076044	006290	023910	011677	005055
A	-1	0					

Figure 5. Algorithm C - Data Set 2



R	000000	1	1.1118	1.1411
R	100000	3	1.0131	1.0299
R	101000	4	1.0000	1.0000
R	108000	5	0.6667	12.7273
R	109000	6	3.3333	4.9180
R	100000	7	1.0154	1.0323
R	101000	8	1.0021	1.0000
R	101100	9	.9995	1.0000
R	101300	10	1.0285	1.0536
R	101400	11	1.0163	1.0345
R	200000	12	1.4101	1.3544
R	300000	13	1.0304	1.0459
R	310000	14	1.0307	1.0449
R	312400	15	1.0976	1.1182
	.			
	.			
	.			
	.			
	.			
	.			
R	909190	139	0.7485	0.7959
R	909200	145	0.3832	0.4667
R	909300	148	0.4458	0.4642
R	-1	0		

Input Data Sets - Algorithm D

Algorithm D has nine input data sets. Data sets one and eight, the standard industry code structures are discussed elsewhere.

Data set 2 contains the major standard occupation codes. To provide compatability with a data set from a 1401 type, the ninth column of this card is overpunched with a twelve punch. Consequently the numbers in this column appear as alpha characters corresponding to the table below.

<u>Actual Number</u>	<u>Printed Character</u>
0	blank
1	A
2	B
3	C
4	D
5	E
6	F
7	G
8	H
9	I

We display portions of this table for occupation codes 0000-1200 and 7999-9000.

Data set 3 consists of one card indicating levels for occupational charge factors.

Data set 4 contains one card for each industrial code.

We display the data for codes 000000-312140 and 909190-909300.

Note, there is no 0 ending to this data set.

Data set 5 contains occupational code levels. There is one card for every occupational code. We display data for codes 0000-1200 and 7999-9000. As with data set 4, there is no 0 terminator to this set.

Data set 6, industrial employment ratios, contains one card for every industrial code. We display data for codes 000000-313400 and 900000-909100 as well as the 0 terminator.

Data set 7, which is of the same format as data set 6, is not shown.

Data set 9 is the national BLS industrial occupational matrix tape. Its format is described in literature provided by the Bureau of Labor Statistics.

INPUT DATA SETS - ALGORITHM D

1. Major Standard Industry Code Structure (XV:A)

Maximum code index: 156

(cf: Input for Code Structure)

2. Major Standard Occupation Codes (XV:D)

for each occupation code - 1 card containing:

Columns	7-10	11-20
Format	A4	I10
Location	IA	INDEX
Contents	Occupation Code*	Index for Code

Ending with 1 card containing a 0 in columns 11-20

*Note: an "&" (row 12 punch) is overpunched in column 9 of each card in this data set.

3. Industry Levels for Occupational Change Factors (Steps 9, 17, 18, and 19)

1 card containing:

Columns	1-10	11-20	21-30	36	37	38	39	40
Format	I10	I10	I10	L1	L1	L1	L1	L1
Location	IA	IB	IC	Lev(1)	Lev(2)	Lev(3)	Lev(4)	Lev(5)
Contents	"0"	"0"	"0"	T Level II indicator*	Level III indicator	Level IIIA indicator	Level IV indicator	Level V indicator

*Explanation: an indicator of "T" specifies that occupational change factors are to be calculated for the associated industrial level. A blank or "F" specifies the opposite.

4. Industrial Code Levels and National Matrix Sequence

for each of the 157 industrial codes occurring on the national matrix (data set 9). - 1 card containing:

Columns	1-10	11-20	21-30	36	37	38	39	40
Format	I10	I10	I10	L1	L1	L1	L1	L1
Location	IA	IB	IND(I)	ILev (I, 1)	ILev (I, 2)	ILev (I, 3)	ILev (I, 4)	ILev (I, 5)
Contents	Sequence Number*	Industry code	Index for code	Level II indicator**	Level III indicator	Level IIIA indicator	Level IV indicator	Level V indicator

*Note: this is the order of the industry codes on the national matrix and must be in order on the cards. If any code on the national matrix is not used, the index for code is set to -1.

**Explanation: an indicator of "T" specifies that the corresponding industry code occurs on the associated industrial level. A blank or "F" specifies the opposite.

5. Occupational Code Levels

For each of the 187 occupational codes occurring on the national matrix (data set) -1 card containing:

Columns	1-10	11-20	21-30
Format	I10	I10	I10
Location	IA	IB	OCC(I)
Contents	Sequence Number*	Industry Code**	Index for Code

*Note: this is the order of the occupation codes on the national matrix and must be in order on the cards. If any code on the national matrix is not used, the index for code is set to -1.

**Note: an "&" (row 12 punch) is overpunched in column 9 of each card in this data set.

6. Covered Industrial Employment Ratios - 1960 (XIII:A)

For each industry code -1 card containing:

Columns	3-8	10-12	14-19	20-25	26-31	32-37	
Format	I6	I3	F6.4	F6.4	F6.4	F6.4	
Location	IA	INDEX	RA(1)	RA(2)	RA(3)	RA(4)	
Contents	Industry Code	Index for Code	Fraction of Area 28 in Area 3	Fraction of Area 28 in Area 4	Fraction of Area 28 in Area 8	Fraction of Area 29 in Area 7	

(continued)

	38-43	44-49	50-55	56-61	62-67	68-73
	F6.4	F6.4	F6.4	F6.4	F6.4	F6.4
	RA(5)	RA(6)	RA(7)	RA(8)	RA(9)	RA(10)
	Fraction of Area 29 in Area 14	Fraction of Area 29 in Area 20	Fraction of Area 30 in Area 2	Fraction of Area 30 in Area 16	Fraction of Area 31 in Area 12	Fraction of Area 31 in Area 18

Ending with one card containing a zero in columns 10-12.

- 7. Covered Industrial Employment Ratios - 1975 (XIII:A)
Using the same format as in data set 6.
- 8. Major Standard Occupation Code Structure (XV:D)
Maximum code index: 186
(cf: Input for Code Structure)
- 9. National B. L. S. Industrial Occupational Matrix Tape (XVI)
As provided by the Bureau of Labor Statistics

00 0	0001
10 0	0002
11 0	0003
11A0	0004
11B0	0005
11C0	0006
11D0	0007
11E0	0008
11F0	0009
11G0	0010
11H0	0011
11I9	0012
12 0	0013

7919	0184
80 0	0185
90 0	0186
	0

Figure 7. Algorithm D - Data Set 2

TFFFF

Figure 8. Algorithm D - Data Set 3

1	000000	1	
2	010000	3	TTT
3	101000	4	TT
4	010800	5	TT
5	010900	6	TT
6	100000	7	TTT
7	101000	8	TT
8	101100	9	TT
9	101300	10	TT
10	101400	11	TT
11	200000	12	TTTTT
12	300000	13	T
13	310000	14	T
14	312400	15	TT
155	909190	139	T
156	909200	145	TT
157	909300	146	TT

Figure 9. Algorithm D - Data Set 4

1	00 0	1
2	10 0	2
3	11 0	3
4	11A0	4
5	11B0	5
6	11C0	6
7	11D0	7
8	11E0	8
9	11F0	9
10	11G0	10
11	11H0	11
12	11I9	12
13	12 0	13
	.	
	.	
	.	
185	7919	184
186	80 0	185
187	90 0	186

I	0	1	02286	06388	01326	05983	00964	03053	05777	04223	07800	02200
I	10000	3	03705	04103	02190	03091	02594	04313	07535	02464	08194	01805
I	10100	4	03705	04103	02190	03091	02594	04313	07535	02464	08194	01805
I	10800	5										
I	10900	6							10000			
I	100000	7	01619	06307	02012	00876	07954	01168	01342	08658	03954	06045
I	101000	8					10000			10000		
I	101100	9										
I	101300	10		10000								
I	101400	11	01786	05980	02232	01733	05956	02310	01375	08624	03954	06045
I	200000	12	03191	05342	01465	05316	01189	03494	06985	03014	07700	02299
I	300000	13	02140	06501	01358	05525	00942	03532	05288	04711	07803	02196
I	310000	14	02381	07129	00489	05365	00828	03806	06302	03697	07328	02671
I	312400	15	03855	04399	01745	04960	02380	02659	05743	04256	08810	01189
I	312500	18	01446	07670	00883	05400	00249	04349	02966	07033	09717	00282
I	313200	19	01493	07764	00742	04609	02957	02433	07267	02732	03505	06494
I	313300	25	08429	01262	00308	03452	00965	05581	05785	04214	09713	00286
I	313400	29	00841	06915	02243	05295	00605	04098	04726	05273	09732	00267
.												
.												
.												
I	322900	67	00067	00471	09461	01337	00141	08521	09499	00501	07147	02852
I	323000	70	07158	02791	00049	03900	03110	02988	01101	08899	08968	01031
I	323100	73	02805	07179	00015	07146	01703	01150	05035	04964	10000	
I	400000	78	03120	05336	01542	07397	00665	01937	06156	03843	08427	01572

Input Data Sets - Algorithm E

There are five input data sets for algorithm E. Data sets one through three are segments of the occupational code structure, discussed elsewhere.

Data set 4 contains part of the April 1, 1960 census occupational employment. For each of fourteen areas, this matrix displays employment statistics by occupational codes. We display segments of data for areas 1 (first area), 29, and 12 (the last area).

Data set 5 contains the remainder of the April 1, 1960 census occupational employment data. We display all of the data for area 5 (the first area) and segments of the data for area 18 (the last area).

INPUT DATA SETS - ALGORITHM E

1. Major Standard Occupational Code Structure (XV:D)
 - including codes 9010, 9020, and 0999
 - Maximum code index: 200
 - (cf: Input for Code Structures)

2. Special Occupational Code Structure, Level IIOS, IIIOS, VOS, and VIOS for Male Minor County Data (XV:E)
 - Include all codes in IVOS in list but not in structure.
 - Maximum code index: 200
 - (cf: Input for Code Structure)

3. Special Occupational Code Structure, Levels IIOS, IIIOS, IVOS, and VIOS for Female Minor County Data (XV:E)
 - Maximum code index: 200
 - (cf: Input for Code Structure)

4. April 1st 1960 Census Occupational Employment
 - For each area: 0, 29, 30, 9, 11, 1, 13, 7, 14, 20, 2, 16, 4, and 12 (in this order):
 - For each code in the standard occupational code structure for which data is available - 1 card containing:

Columns	5-10	12-20	22-30	32-40
Format	I6	I9	I9	I9
Location	IA	INDEX	IB	IC
Contents	Industry Code	Index for Code	Male Employment	Female Employment

At the end of the employment data for each area:

1 card containing 0 in columns 12-20.

5. April 1st 1960 Census Occupational Employment

For each area: 5, 6, 10, 15, 17, 19, 21, 3, 8, and 18 (in this order):

For each code in the special occupational code structure for which data is available (male or female)-
1 card using the same format as in data set 4.

At the end of the employment data for each area:

1 card containing 0 in columns 12-20.

0 1	999	189	78191.	46570.
0 1	1000	2	198657.	93083.
0 1	1100	3	46381.	294.
0 1	1110	4	1379.	23.
0 1	1120	5	3924.	24.
0 1	1130	6	5324.	25.
0 1	1140	7	13784.	161.
0 1	1150	8	4734.	54.
0 1	1160	9	8333.	28.
0 1	1170	10	706.	8.
0 1	118	11	91.	0.
0 1	1199	12	3775.	4.
0 1	1199	12	4331.	27.
0 1	1210	14	3472.	67.

0 1	8000	185	89904.	3472.
0 1	9010	187	12664.	1266.
0 1	9020	188	10277.	2202.
0 1	-1	0		
0 2		1	452334.	228190.
0 2	999	189	29622.	18225.

0 2	9020	188	878	147
0 2	-1	0		

014		1	114481	49108
014	1000	2	14429	5607

014	9010	187	483	40
014	9020	188	570	105
014	-1	0		



015	0	1	10168.	4891.
015	999	189	740.	446.
015	1000	2	720.	562.
015	1099	191	0.	68.
015	1099	191	0.	16.
015	1099	191	322.	0.
015	1099	191	100.	0.
015	1100	3	75.	0.
015	1209	192	51.	0.
015	1209	192	99.	146.
015	1209	192	0.	28.
015	1309	193	73.	304.
015	2000	62	1415.	249.
015	3000	69	521.	1241.
015	3099	195	0.	940.
015	3100	70	0.	301.
015	4000	82	830.	456.
015	5000	83	2516.	50.
015	5099	196	429.	0.
015	5100	84	1223.	0.
015	5200	95	153.	0.
015	5300	96	53.	0.
015	5400	107	658.	0.
015	6000	136	1378.	626.
015	6099	197	204.	0.
015	6099	197	197.	0.
015	6099	197	419.	0.
015	6200	137	558.	0.
015	7000	167	916.	837.
015	7098	198	0.	488.
015	7100	168	19.	384.
015	7200	169	309.	0.
015	7300	173	199.	349.
015	7900	178	408.	0.
015	8000	185	872.	16.
015	9010	187	180.	16.
015	9020	188	61.	8.
015	-1	0		

024		1	38710.	17740.
024	999	189	1205.	834.
024	1000	2	6567.	2721.
024	9020	188	437.	72.
024	-1	0		

Input Data Sets - Algorithm F

There are three input data sets for algorithm F. Data set three, occupation code structures is described elsewhere.

Data sets one and two contain April 1, 1960 census occupational employment commutation data and control figures. The formats of these matrices are analogous to the corresponding industrial employment commutation matrices described in the discussion of algorithm B. For completeness, we display selected portions of data set 1 as well as all of data set 2.

INPUT DATA SETS - ALGORITHM F

1. April 1st 1960 Census Occupational Employment Commutation (X:B)

For each from-area 1-26 except 22

For each to-area except 22

1 card containing:

Column	2	4-5	7-8	12-19	20-24	25-29	30-34	
Format	A 1	I2	I2	I8	F5.3	F5.3	F5.3	
Location	IA	IB	IC	ID	ACC(2)	ACC(3)	ACC(4)	
Contents	Occupational identifier "0"	from-area code	to-area code	total commuting	fraction in 1000	fraction in 0290	fraction in 4000	

	35-39	40-44	45-49	50-54	55-59	60-64
	F5.3	F5.3	F5.3	F5.3	F5.3	F5.3
	ACC(5)	ACC(6)	ACC(7)	ACC(8)	ACC(9)	ACC(10)
	fraction in 3000	fraction in 5000	fraction in 6000	fraction in 7100	fraction in 7000	fraction in 0890

2. April 1st 1960 Census Occupational Employment Commutation Control Figures (XI:B)

For each area in II-G: 29, 30, 9, 11, 33 (in this order):

1 card containing:

Columns	1-2	4-5	8-14	15-20	21-26	27-32	33-38	
Format	A2	I2	I7	I6	I6	I6	I6	
Location	IA	IC	ACC(1)	ACC(2)	ACC(3)	ACC(4)	ACC(5)	
Contents	identifier "CA"	area code	0000	e m p l o y m e n t 1000	i n 0290	4000	3000	

	39-44	45-50	51-56	57-62	63-68
	I6	I6	I6	I6	I6
	ACC(6)	ACC(7)	ACC(8)	ACC(9)	ACC(10)
	5000	6000	7100	e m p l o y m e n t 7000	i n 0890

3. Special Occupation Code Structure (XV:E), Levels IOS and VIOS.

Maximum Code index: 200

(cf: Input for Code Structures)

0 01 01	00051703										
0 01 02											
0 01 03	00000532	0109	0055	0044	0097	0251	0303	0009	0050	0080	
0 01 04	00001705	0109	0055	0044	0097	0251	0303	0009	0050	0080	
0 01 05	00001003	0109	0055	0044	0097	0251	0303	0009	0050	0080	
0 01 06	00002250	0109	0055	0044	0097	0251	0303	0009	0050	0080	
0 01 07											
0 01 08	00000302	0109	0055	0044	0097	0251	0303	0009	0050	0080	
0 01 09											
0 01 10											
0 01 11	00000132	0245	0103	0065	0074	0293	0116	0008	0034	0062	
0 01 12											
0 01 13											
0 01 14											
0 01 15	00000234	0109	0055	0044	0097	0251	0303	0009	0050	0080	
0 01 16											
0 01 17	00000132	0169	0092	0061	0063	0271	0247	0002	0030	0064	
0 01 18											
0 01 19											
0 01 20											
0 01 21											
0 01 23	00001701	0216	0137	0140	0091	0172	0163	0004	0039	0039	
0 01 24	00000178	0242	0251	0115	0159	0112	0073	0005	0028	0015	
0 01 25	00000044	0169	0092	0061	0063	0271	0247	0002	0030	0064	
0 01 26	00000139	0242	0251	0115	0159	0112	0073	0005	0028	0015	
0 02 01											
0 02 02	00162878										
0 02 03	00000053	0216	0137	0140	0091	0172	0163	0004	0039	0039	
...											
0 02 26	00002517	0232	0191	0112	0122	0196	0102	0001	0025	0019	
...											
0 26 01											
0 26 02	00001080	0160	0125	0074	0093	0221	0260	0003	0024	0039	
0 26 03	00000710	0203	0129	0072	0070	0222	0186	0004	0051	0064	
...											
0 26 26											

Figure 14. Algorithm F - Data Set 1



CA 29	60072	96056	0.46	54643126793105717146975	15171051967	27596
CA 30	39483	49088	39.67	31856 63992 64110100068	6938027245	15417
CA 09	254415	23344	2.187	15019 40960 39662 76701	1680020620	16242
CA 11	119429	17349	1.40	7898 21268 17864 25583	2593010766	5867
CA 33	708597	81343	63.27	518921 1746120793161127	16178066020	46272

Input Data Sets - Algorithm G

Algorithm G has two input data sets. Data set one is a portion of the standard occupational code structure described elsewhere.

Data set two is the estimated 1960 occupational death and retirement rates. We display the estimated rates for occupational codes 1110-1210 and 7210-9000 as well as the 0 terminator.

INPUT DATA SETS - ALGORITHM G

1. Major Standard Occupational Code Structure (XV:D)

Maximum code index: 200

(cf: Input for Code Structures)

2. Estimated New Jersey 1960 Occupational Death and Retirement Rates (XIV)

For each occupational code - 1 card containing:

Columns	1-10	11-20	21-30
Format	I10	I10	F10.8
Location	IA	INDEX	VA
Contents	Occupational Code	Index for Code	Death and retirement rate

1110	4	.0070
1120	5	.0090
1130	6	.0190
1140	7	.0100
1150	8	.0110
1160	9	.0140
1170	10	.0120
1180	11	.0140
1199	12	.0130
1210	14	.0200

.
. .
. . .

7210	170	.0260
7220	171	.0140
7230	172	.0430
7310	174	.0260
7320	175	.0300
7330	176	.0360
7340	177	.0400
7910	179	.0360
7920	180	.0390
7930	181	.0430
7940	182	.0420
7950	183	.0550
7999	184	.0320
8000	185	.0180
9000	186	.0220
-1	0	

INPUT FOR CODE STRUCTURES

In order to provide some generality for the preparation of employment input data, industry and occupation code structures are specified through data sets. This requires that the user have an understanding of the internal representation of these structures. Two concepts are central to this discussion; one is the category numbering scheme and the other is the structure format.

Each industry code is assigned a unique internal index from 1 to N where N is the number of industry codes used in the algorithms. Similarly each occupation code is assigned a unique internal index from 1 to M where M is the number of occupation codes used in the algorithms. In each case, index 1 must be used for the fully aggregated employment (codes 000000 or 0000 respectively); otherwise the numbering is fairly arbitrary.* These indices are used whenever data related to employment code are provided in the input. It is not intended that the user should change the numbering supplied with the initial data sets. If he wishes to, he should review the data and initialization statements and adjust these as may be required.

The code structures are used for aggregating and disaggregating employment figures. Consequently they can be represented as trees. An example of such a tree is shown in the following figure:

*It is desirable to assign the highest industry indices to codes which occur only in the special industry structure.

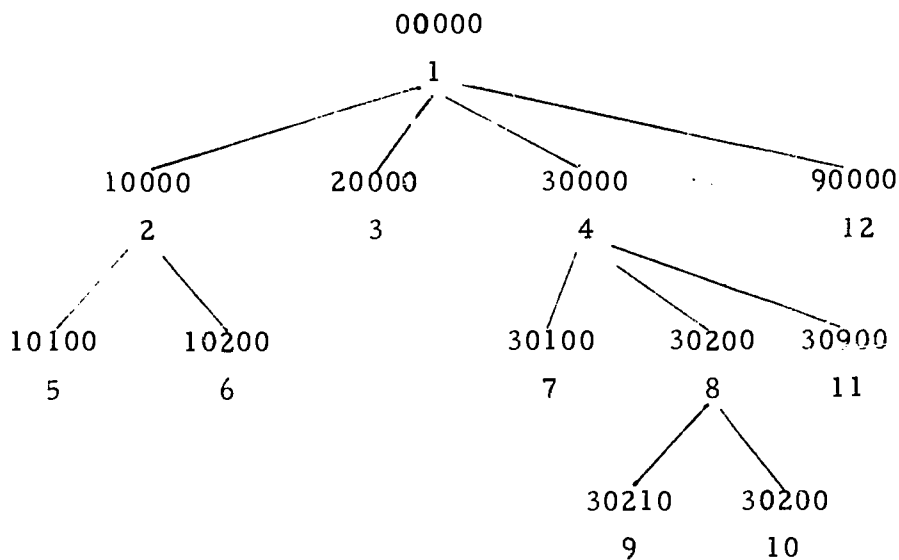

Under each code is shown the index which has been assigned. For internal computations it will be important to be able to scan through the tree rapidly. In order to represent the structure efficiently, it is convenient to represent the tree in a particular format. To assist this explanation, the above tree has been reformatted in the desired manner in the following figure:

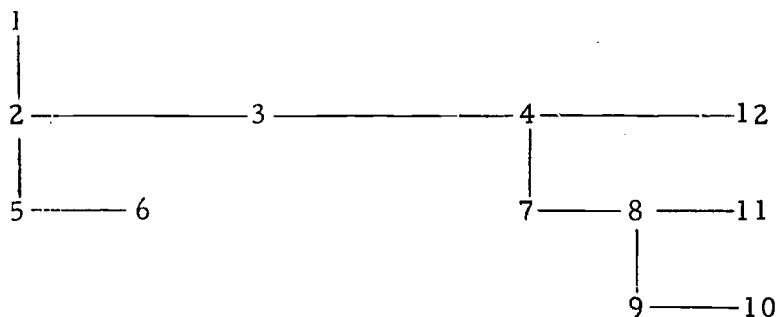

The codes have been omitted as only the indices are used in describing the structure.

Input data sets are prepared in exactly this format with one card for each index. The order is arbitrary and the last card is followed by one with a 0 as the index and a -1 as the code (the latter is optional). The format is:

for each code - 1 card containing:

Columns	1-10	11-20	21-30	31-40	45-60
Format	I10	I10	I10	I10	2A8
Location	IA	INDEX	I B	IC	ID
Contents	code	index	across index	down index	name (optional)

ending with 1 card containing a 0 in columns 11-20.

The input data set number 3 of algorithm A is used as an example in Figure 17 of the preparation of a code structure for input. It is used for minor county data with special industry codes. The structure with the internal codes is shown below:

<u>Level I</u>	<u>Level II</u>	<u>Level III</u>	<u>Level IV</u>
000000 1	001111 161	010000 3	010100 4
			010800 5
			010900 6
		100000 7	

(continued)

Level I

Level II

Level III

Level IV

200000

12

300000

13

310000

14

320000

44

400000

78

500000

101

600000

127

700000

132

900000

110

009999

167

000000	1	0	161
001111	161	12	3
009999	167	0	0
010000	3	7	4
010100	4	5	0
010800	5	6	0
010900	6	0	0
100000	7	0	0
200000	12	13	0
300000	13	78	14
310000	14	44	0
320000	44	0	0
400000	78	101	0
500000	101	127	0
600000	127	132	0
700000	132	110	0
900000	110	167	0
-1	0	0	0

RUNNING INSTRUCTIONS

A complete set of programs, data, and controls are provided in the ten boxes of cards furnished with this data. These are organized for use on an RCA Spectra 70/model 45 and have been run on that machine for verification. The operating philosophy has been designed on the premises that ease of use should be the first consideration and that runs will be made infrequently.

The seven algorithms are encoded in seven separate programs. Each algorithm is organized as shown in Figure 18 into 5 parts. First is a set of control cards designating the job and initiating the compilation of the Fortran programs which come second.* Third are control cards defining the external data sets (tapes, cards, and printed reports). These first three sets need never be changed in normal usage.

The fourth part is the data which is prepared according to the specifications contained in the other sections of this chapter. Part or all of the data provided can be replaced as corrections are made and as new data is obtained.

The last card is the `//_ENDMON` card advising the system to close out the current job. It also is always present.

The control cards used for each of the seven algorithms are shown in Figures 20 through 26. To reduce superfluous output and execution time the `//_PARAM` cards can be replaced with one card

* Source decks rather than object decks are used to simplify the use and maintenance of the programs.

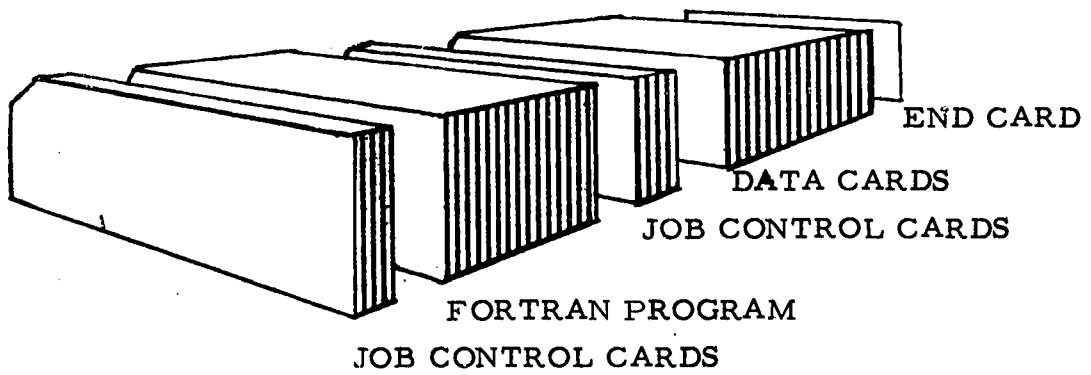

FIGURE 18. SAMPLE ALGORITHM DECK SET-UP

containing:

```
//_PARAM-MAP=NO
```

preceding the `//_EXEC_FORTRAN` card.

No other changes should be made.

The program follows the "PROGRAM" card and the data follows the `//_EXEC` card.

After preparing the seven algorithms in this manner, they are submitted to the computer center together with the national matrix tape and the flow chart shown in Figure 19. This chart provides the operator with the information he needs to execute the programs and obtain the printed reports for the user. A block of approximately two hours should be reserved and instructions should be left for the return of input and output materials.

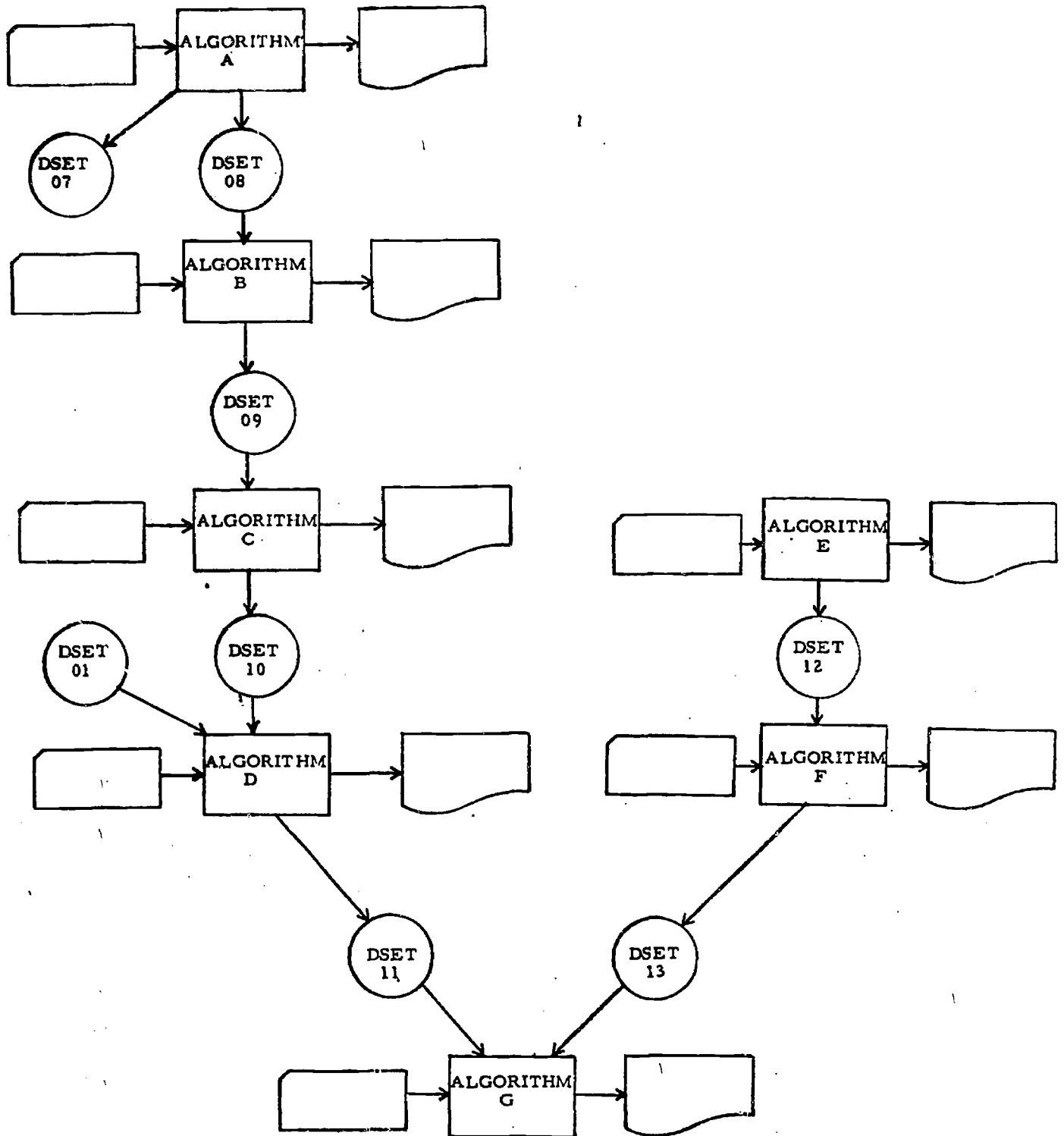

DSET01 is the national matrix tape. All other tapes are generated from scratch during the run and need to be saved only if the following algorithms are to be run again. The printed output can be placed on tape and printed at a later time.

Core requirements are less than 100K except for algorithm D which needs approximately 125K.

FIGURE 19. JOB FLOW CHART

```

// STARTM
// JOB X11 FREEDMAN
// PARAM LIST=YES
// PARAM DEBUG=YES
// EXEC FORTRN
    PROGRAM ALG A
// ASSMBL
SLR.DAT1  START
          PRINT NOGEN
          DATAD DCBEQU=DS 97,DEVADDR=SYSIPT,DSREF=5
          DATAD DSREF=9,DEVICE=TAPE,RECFORM=VARUNB,RECSIZE=672,      X
                BLKSIZE=680,VOLUME=FILEA
          DATAD DSREF=9,DEVICE=TAPE,RECFORM=VARUNB,RECSIZE=708,      X
                BLKSIZE=716,VOLUME=FILEB
          DATAD DCBEQU=DS 99,DEVADDR=SYSLST,DSREF=6
DS 97     DATAD DEVICE=MONITOR,DEVADDR=SYSIPT,DSREF=97
DS 99     DATAD DEVICE=MONITOR,DEVADDR=SYSLST,DSREF=99,CONTROL=SYSTEM
          DATAD
          END

// EXEC
// ENOMON

```

```

// STARTM
// JOB X11 FREEDMAN
// PARAM DEBUG=YES
// EXEC FORTRN
    PROGRAM ALG B
// ASSMBL
SLRDATA1  START
          PRINT NOGEN
          DATAD DCBEQU=DS 97,DEVADDR=SYSIPT,DSREF=5
          DATAD DSREF=9,DEVICE=TAPL,RECFORM=VARUNB,RECSIZE=708,      X
                BLKSIZE=716,VOLUME=FILEB
          DATAD DSREF=10,DEVICE=TAPE,RECFORM=VARUNB,RECSIZE=712,    X
                BLKSIZE=720,VOLUME=FILEC
          DATAD DCBEQU=DS 99,DEVADDR=SYSLST,DSREF=6
DS 97     DATAD DEVICE=MONITOR,DEVADDR=SYSIPT,DSREF=97
DS 99     DATAD DEVICE=MONITOR,DEVADDR=SYSLST,DSREF=99,CONTROL=SYSTEM
          DATAD
          END
// EXEC
// ENDMCA

```

```

// STARTM
// JOB X11 FREEDMAN
// PARAM LIST=YES
// PARAM DEBUG=YES
// EXEC FORTRN
    PROGRAM ALG D
// ASSEMBL
SLR.DAT1  START
    PRINT NOGEN
    DATAD DCBEQU=DS 97,DEVADDR=SYSIPT,DSREF=5
    DATAD DSREF=1,DEVICE=TAPE,RECFORM=FIXBLK,RECSIZE=77,      X
          BLKSIZE=770,VOLUME=NATMAT
    DATAD DSREF=11,DEVICE=TAPE,RECFORM=VARUNB,RECSIZE=668,   X
          BLKSIZE=676,VOLUME=FILED
    DATAD DSREF=12,DEVICE=TAPE,RECFORM=VARUNB,RECSIZE=804,   X
          BLKSIZE=812,VOLUME=FILEE
    DATAD DCBEQU=DS 99,DEVADDR=SYSLST,DSREF=6
DS 97    DATAD DEVICE=MONITOR,DEVADDR=SYSIPT,DSREF=97
DS 99    DATAD DEVICE=MONITOR,DEVADDR=SYSLST,DSREF=99,CONTROL=SYSTEM
    DATAD
    END
// EXEC
// ENDMON

```

```

// STARTM
// JOB X11 FREEDMAN
// PARAM LIST=YES
// PARAM DEBUG=YES
// EXEC FURTRN
    PROGRAM ALG E
// ASSMBL
SLRDATA1 START
    PRINT NOGEN
    DATAD DCBEQU=DS 97,DEVADDR=SYSIPT,DSREF=5
    DATAD DSREF=13,DEVICE=TAPE,RECFORM=VARUNB,RECSIZE=804,      X
        HLKSIZE=12,VOLUME=FILEF
    DATAD DCBEQU=DS 99,DEVADDR=SYSLST,DSREF=6
DS 97    DATAD DEVICE=MONITOR,DEVADDR=SYSIPT,DSREF=97
DS 99    DATAD DEVICE=MONITOR,DEVADDR=SYSLST,DSREF=99,CONTROL=SYSTEM
    DATAD
    END
// EXEC
// ENDMON

```

```

// STARTM
// JOB XII FREEDMAN
// PARAM LIST=YES
// PARAM DEBUG=YES
// EXEC FORTRN
    PROGRAM ALG F
// ASSMBL
SERDAT1  START
        PRINT NOGEN
        DATAD DCBEQU=DS 97,DEVADDR=SYSIPT,DSREF=5
        DATAD DSREF=13,DEVICE=TAPE,RECFORM=VARUNB,RECSIZE=804,      X
              BLKSIZE=812,VOLUME=FILEF
        DATAD DSREF=14,DEVICE=TAPE,RECFORM=VARUNB,RECSIZE=804,      X
              BLKSIZE=812,VOLUME=FILEG
        DATAD DCBEQU=DS 99,DEVADDR=SYSLST,DSREF=6
05 97  DATAD DEVICE=MONITOR,DEVADDR=SYSIPT,DSREF=97
05 99  DATAD DEVICE=MONITOR,DEVADDR=SYSLST,DSREF=99,CONTROL=SYSTEM
        DATAD
        NO
// EXEC
// ENDMON

```

```

// STARTM
// JOB X11 FREEDMAN
// PARAM LIST=YES
// PARAM DEBUG=YES
// EXEC FORTRN
    PROGRAM ALG G
// ASSMBL
SLRDATA1  START
          PRINT NOGEN
          DATAD DCBEQU=DS 97,DEVADDR=SYSIPT,DSREF=5
          DATAD DSREF=12,DEVICE=TAPE,RECFORM=VARUNB,RECSIZE=804,      X
                BLKSIZE=812,VOLUME=FILEE
          DATAD DSREF=14,DEVICE=TAPE,RECFORM=VARUNB,RECSIZE=804,      X
                BLKSIZE=812,VOLUME=FILEG
          LATAD DCBEQU=DS 99,DEVADDR=SYSLST,DSREF=6
DS 97     DATAD DEVICE=MONITOR,DEVADDR=SYSIPT,DSREF=97
DS 99     DATAD DEVICE=MONITOR,DEVADDR=SYSLST,DSREF=99,CONTROL=SYSTEM
          DATAD
          END

// EXEC

// ENDMON

```

D. OUTPUT REPORTS

Each of the algorithms A through G, produces a number of reports. In this section we list all of the reports produced by each of the algorithms and display sample reports for each report type.

Output Reports - Algorithm A

Output reports 1 through 14 have identical formats. Report number 1, which contains totals for all of New Jersey, is displayed for selected values of industry code. Note: if industry 1 occupational names have been input they would appear in the reports following the codes.

Output reports 15 through 24 also have identical formats. Consequently we display only report number 15, for the Cape May area.

<u>Number</u>	<u>Title</u>	<u>Area</u>	<u>Results from Step</u>	<u>Industry Level</u>
1	Census Total Both Sexes Industrial Employment	New Jersey	21	VIII
2	Census Total Both Sexes Industrial Employment	Newark	21	VIII
3	Census Total Both Sexes Industrial Employment	Paterson, et al	21	VIII
4	Census Total Both Sexes Industrial Employment	Hudson	21	VIII
5	Census Total Both Sexes Industrial Employment	Mercer	21	VIII
6	Census Total Both Sexes Industrial Employment	Atlantic	21	VIII
7	Census Total Both Sexes Industrial Employment	Monmouth	21	VIII
8	Census Total Both Sexes Industrial Employment	Essex	21	VIII
9	Census Total Both Sexes Industrial Employment	Morris	21	VIII
10	Census Total Both Sexes Industrial Employment	Union	21	VIII
11	Census Total Both Sexes Industrial Employment	Bergen	21	VIII
12	Census Total Both Sexes Industrial Employment	Passaic	21	VIII
13	Census Total Both Sexes Industrial Employment	Camden Co.	21	VIII
14	Census Total Both Sexes Industrial Employment	Middlesex	21	VIII
15	Census Total Both Sexes Industrial Employment	Cape May	31	VS
16	Census Total Both Sexes Industrial Employment	Cumberland	31	VS
17	Census Total Both Sexes Industrial Employment	Hunterdon	31	VS
18	Census Total Both Sexes Industrial Employment	Ocean	31	VS
19	Census Total Both Sexes Industrial Employment	Salem	31	VS
20	Census Total Both Sexes Industrial Employment	Sussex	31	VS
21	Census Total Both Sexes Industrial Employment	Warren	31	VS
22	Census Total Both Sexes Industrial Employment	Burlington	31	VS
23	Census Total Both Sexes Industrial Employment	Gloucester	31	VS
24	Census Total Both Sexes Industrial Employment	Somerset	31	VS

REPORT NUMBER 1

APRIL 1, 1960, CENSUS TOTAL BOTH SEXES INDUSTRIAL EMPLOYMENT

	JERSEY	NEW
0	2345496	
1111	39547	
10060	35840	
10100	34527	
10800	183	
10900	1131	
100900	3707	
101000	947	
101100	169	
101300	407	
101400	2184	
200300	135661	
300300	886723	
310300	458952	
312400	5912	
312411	336	
312420	5276	
312500	9774	
313200	34107	
900000	108796	
909100	53335	
909120	19219	
909190	34116	
909200	13644	
909300	41816	
9599	0	

REPORT NUMBER 15

APRIL 1, 1960, CENSUS TOTAL BOTH SEXES INDUSTRIAL EMPLOYMENT
CAPE MAY

0	15059
1111	688
10000	639
10100	386
10800	0
10900	252
100000	50
200000	2015
300000	2376
310000	834
320000	1241
400000	1409
500000	3438
600000	853
700000	3552
900000	1029
9999	0

Output Reports - Algorithm B

Output report number 1, reproduced in its entirety, contains net industrial commutation figures.

Output reports 2, 3, 4, 5, 8, and 9, which are all in the same format, are represented by selected portions of report number 2 which is April 1, 1960 total industrial employment for Newark.

Output reports 7, and 10-16, are all in the same format and are represented by the complete report 7 for Perth Amboy.

Algorithm B

<u>Number</u>	<u>Title</u>	<u>Area*</u>	<u>Results from Step</u>	<u>Industry Level</u>
1.	April 1, 1960, Net Commutation by Industry	VG	11	III S
2.	April 1, 1960, Total Industrial Employment (Establishment Basis)	Newark	34	V
3.	April 1, 1960, Total Industrial Employment (Establishment Basis)	Paterson, et al.	34	V
4.	April 1, 1960, Total Industrial Employment (Establishment Basis)	Hudson	34	V
5.	April 1, 1960, Total Industrial Employment (Establishment Basis)	Mercer	34	V
6.	April 1, 1960, Total Industrial Employment (Establishment Basis)	Camden LMA	35	II
7.	April 1, 1960, Total Industrial Employment (Establishment Basis)	Perth Amboy, et al	35	II
8.	April 1, 1960, Total Industrial Employment (Establishment Basis)	Atlantic	34	V
9.	April 1, 1960, Total Industrial Employment (Establishment Basis)	Monmouth	34	V
10.	April 1, 1960, Total Industrial Employment (Establishment Basis)	Cape May	35	II
11.	April 1, 1960, Total Industrial Employment (Establishment Basis)	Cumberland	35	II
12.	April 1, 1960, Total Industrial Employment (Establishment Basis)	Hunterdon	35	II
13.	April 1, 1960, Total Industrial Employment (Establishment Basis)	Ocean	35	II
14.	April 1, 1960, Total Industrial Employment (Establishment Basis)	Salem	35	II
15.	April 1, 1960, Total Industrial Employment (Establishment Basis)	Sussex	35	II
16.	April 1, 1960, Total Industrial Employment (Establishment Basis)	Warren	35	II

*Area VG includes all 21 counties plus Pennsylvania, New York, Delaware, and "Elsewhere".

REPORT NUMBER 1

ALGORITHM B

APRIL 1, 1960, NET COMPUTATION BY INDUSTRY ATLANTIC BERGEN

	BURLING -TKN	CAMDEN CC	CAPE MAY -LAND	CUMBER -LAND	ESSEX	GLUCES -TKN	HUDSON	PUNTER -DOH
C								
1111	-834	-203CC	-856	2154	27169	-15577	1893	-4745
200000	104	146	-10	53	-265	-70	-178	73
300000	307	-247	-101	112	-430	-959	-1280	-462
400000	607	-4428	-270	1348	6423	-1035	14037	-1887
500000	-502	-3372	-115	90	2765	-1341	4822	-666
600000	-310	-3280	-107	263	6640	-2359	-2643	-691
700000	-751	-3270	-31	24	8302	-1087	-7423	-286
710000	-173	-2594	-156	209	1267	-2208	-5137	-388
720000	-203	-937	-29	25	-233	-449	-1494	-206
730000	312	694	-16	33	-281	-190	-498	-87
740000	46	36	-78	0	-352	-60	-566	-33
900000	-331	-2388	-92	150	2136	-1507	-2577	-461
	-174	-1453	-63	51	3524	-553	-103	-236

APRIL 1, 1960, NET COMPUTATION BY INDUSTRY MERCER MIDDLE MONMOUTH MORRIS

	MERCER -SEX	MIDDLE -SEX	MONMOUTH	MORRIS	OCEAN	PASSAIC	SALEM	SOMER -SET	SUSSEX	UNION
C										
1111	11889	-28408	-25546	-12932	-7735	192	362	-10427	-4396	-8644
200000	8	-89	-163	-34	-58	-128	12	-80	-6	60
300000	1869	-1274	-1406	-476	-542	57	160	-621	-249	785
400000	3262	-12335	-9556	-2584	-2314	1454	379	-4606	-2373	2742
500000	659	-3580	-3538	-2172	-1001	-472	-62	-933	-352	-3154
600000	1899	-4155	-3592	-1044	-1044	745	-28	-1505	-623	-2288
700000	714	-2750	-2511	-2346	-691	-603	-70	-751	-346	-4788
710000	2478	-3742	-3917	-1915	-1165	-66	50	-1629	-571	-852
720000	549	-1444	-1279	-348	-364	-377	-15	-577	-184	582
730000	246	-364	-365	-147	-116	-491	26	-190	-83	258
740000	24	-133	-253	-128	-76	-51	0	-62	-18	-106
900000	1508	-1800	-2018	-1290	-608	853	39	-799	-285	-1566
	1016	-577	-862	-566	-298	-92	-79	-299	-72	-1149

APRIL 1, 1960, NET COMPUTATION BY INDUSTRY PENN-NEW YORK DELAWARE ELSE

	WARREN	SYLVANIA	NEW YORK	DELAWARE	ELSE -WHERE
C					
1111	-1227	31703	128214	-68	21582
200000	-104	-108	842	-32	167
300000	21	395	5864	-24	1073
400000	-255	11461	25151	4	6503
500000	-157	5000	15529	16	3031
600000	-159	4953	20781	13	3047
700000	-170	4432	25416	55	2592
710000	-72	3646	28950	-70	4853
720000	-68	1166	8145	5	1283
730000	2	-828	2500	-48	336
740000	-32	17	2521	-7	346
900000	-71	1916	13778	-21	2087
			3679	-24	711

REPORT NUMBER Z
APRIL 1, 1960, TOTAL INDUSTRIAL EMPLOYMENT (ESTABLISHMENT BASIS)
NEWARK

0	686075
1111	4670
10000	3763
10100	3709
10800	34
10900	19
100000	907
101000	440
101100	51
101300	46
101400	371
200000	33213
300000	265525
310000	154890
312400	1584
312411	19
900000	27817
909100	11752
909120	5750
909190	6042
909200	2028
909300	13597
9999	0



REPORT NUMBER 6

APRIL 1, 1960, TOTAL INDUSTRIAL EMPLOYMENT (ESTABLISHMENT BASIS)

CAMDEN

LMA

234758

6280

16608

99588

13359

40345

7605

40555

3730

5392

891

12689

10418

0

1111

20000

30000

40000

50000

60000

700000

710000

720000

730000

740000

900000

Output reports - Algorithm C

Algorithm C output reports are all basically of the same format. They are all in two parts. Part one contains data for areas New Jersey - Cape May, part two contains data for areas Cumberland - Warren.

Representative segments of reports 1, 2, and 12 have been reproduced here.

It should be noted that reports 1, 3, 6, and 14 are basically printouts of input sets.

Algorithm C

<u>Number</u>	<u>Title</u>	<u>Areas</u>	<u>Results from Step</u>	<u>Industry Level **</u>
1	March 1960 CES Industrial Employment	III G	3	V or IIIA
2	Adjusted March 1960 CES Industrial Employment	III G	18	V or IIIA
3	April 1960 CES Industrial Employment	III G	19	V or IIIA
4	Adjusted April 1960 CES Industrial Employment	III G	19	V or IIIA
5	Estimated April 1, 1960 CES Industrial Employment	III G	24	V or IIIA
6	Annual 1960 CES Industrial Employment	III G	25	V or IIIA
7	Adjusted Annual 1960 CES Industrial Employment	III G	25	V or IIIA
8	Industrial Employment Calendar Change Ratios	III G	26	V or IIIA
9	Annualized Census Industrial Employment	III G	27	V or IIIA
10	Ratios of Total to Wage and Salary Industrial Employment	III G	31	V or IIIA
11	1960 Total Industrial Employment	III G	33	V or IIIA
12	National Ratios of Industrial Total to Wage and Salary 1960 to 1975 Trend Factors	III G	36	V or IIIA
13	Projected 1975 New Jersey Ratios of Total to Wage and Salary Industrial Employment	III G	38	V or IIIA
14	Projected Annual 1975 CES Industrial Employment	III G	34	V or IIIA
15	Adjusted Annual 1975 CES Industrial Employment	III G	34	V or IIIA
16	Projected 1975 Total Industrial Employment	III G	39	V or IIIA
17	Adjusted 1975 Total Industrial Employment	III G	40	V or IIIA

* III G includes New Jersey, Newark, Paterson, et. al., Hudson, Mercer, Camden LMA, Perth Amboy, et. al., Atlantic, Monmouth, Cape May, Cumberland, Hunterdon, Ocean, Salem, Sussex, Warren.

** For areas Cape May, Cumberland, Hunterdon, Ocean, Salem, Sussex, and Warren data is valid only to level IIIA.

MARCH 1960 CES INDUSTRIAL EMPLOYMENT

	NEWARK	PATERSON ET AL.	HUDSON	MERCER	CAMDEN LMA	P. AMHOY ET AL.	ATLANTIC	MUNMOUTH	C-P-E	WAY
0	673605	366704	260620	110894	192230	18401-	47059	80864	11061	
10000	3100	3000	100	1400	5600	3100	2000	4700	700	
10100	3100	3000	100	1400	5600	3100	1900	4700	600	
10800	1	1	1	1	1	1	1	1	1	
10900	1	1	1	1	1	1	1	1	1	
100000	876	416	1	100	200	700	150	200	150	
101000	453	1	1	1	1	1	1	1	1	
101100	1	1	1	1	1	1	1	1	1	
101300	1	1	1	1	1	1	1	1	1	
101400	1	1	1	1	1	1	1	1	1	
200000	2711	415	1	100	200	700	150	200	150	
300000	83366	17500	5000	5300	9200	7700	3300	4700	1250	
310000	811956	161200	121400	38793	77800	88800	7600	16850	1600	
312400	437329	81529	62200	23823	48100	45886	1750	8600	550	
312411	5700	471	1300	99	600	426	225	100	0	
	100	1	1	1	1	1	1	1	1	

900000	158258	17077	20400	14673	14450	14743	4411	13458	1896	
909100	54788	3900	5000	1705	5900	7100	1350	9500	0	
909120	17258	3563	2115	905	1354	1200	253	1010	0	
909190	37524	337	2326	300	4545	5900	1096	8489	0	
909200	27426	1500	600	9601	2260	2588	493	1584	0	
909300	76044	11677	13800	3367	6290	5055	2567	2375	0	

MARCH 1960 CES INDUSTRIAL EMPLOYMENT

	CUMBER -LAND	HUNTER -DON	OCEAN	SALEM	SUSSEX	WARREN
0	3857	15062	23057	20622	12024	22525
10000	2800	2000	2100	2000	2750	2100
10100	2700	2000	1900	2000	2750	2100
10800	0	0	0	0	0	0
10900	100	0	200	1	1	1
100000	700	100	200	0	270	150
101000	0	0	0	0	0	0
101100	0	0	0	0	0	0
101300	0	0	0	0	0	0
101400	0	0	0	0	0	0
200000	1200	750	2300	450	600	750
300000	19050	4600	3000	10900	2900	11900
310000	10650	2000	850	2600	1070	7250
312400	0	0	0	0	0	0

900000	2392	1555	3655	1800	1366	1316
909100	0	0	0	0	0	0
909120	0	0	0	0	0	0
909190	0	0	0	0	0	0
909200	0	0	0	0	0	0
909300	0	0	0	0	0	0



REPORT NUMBER 2

ALGORITHM C

ADJUSTED MARCH 1960 CES INDUSTRIAL EMPLOYMENT

	NEW JERSEY	NEWARK	PATERSON ET AL.	HUDSON	MERCER	CAMDEN LMA	P. AMBY ET AL.	ATLANTIC	MONMOUTH	CAPE MAY
19000	2059737	673847	366835	260713	110934	192399	184080	47076	80693	11065
10100	38100	3150	3052	102	1422	3693	3158	2031	4775	714
10900	37499	3148	3059	100	1420	5600	3100	1928	4773	600
10900	1	1	1	1	1	1	1	1	1	1
10900	600	1	1	1	1	1	1	101	1	104
10900	3264	678	322	1	77	155	543	126	155	116
101000	552	350	1	0	1	1	1	1	1	0
101100	1	1	1	0	1	1	1	1	1	0
101300	1	1	1	0	1	1	1	1	1	0
101400	1	1	1	0	1	1	1	1	1	0
200000	2710	327	320	0	75	200	700	174	153	0
300000	83366	24216	17253	4937	5218	9063	7601	32	4626	3236
310000	811356	245174	160991	121436	38685	77636	88796	7574	16801	1604
312400	437329	140019	81634	62351	23794	48078	4005	1749	8524	553
	5700	1258	387	1061	73	481	328	157	77	41

	CUMBERLAND	HUNTER	OCEAN	SALEM	SUSSEX	WARREN
900000	158258	45365	17032	20377	14613	14400
909100	54788	16830	3890	4994	1698	5900
909120	17260	5556	3554	2378	901	1354
909190	37528	11274	336	2616	797	4545
909200	27426	4724	1496	599	9562	2260
909300	76044	23811	11646	14783	3353	6290

ADJUSTED MARCH 1960 CES INDUSTRIAL EMPLOYMENT

	CUMBERLAND	HUNTER	OCEAN	SALEM	SUSSEX	WARREN
10000	38671	15067	23065	20629	12028	22533
10100	2860	2035	2136	2034	2800	2138
10800	2700	2000	1900	2000	2750	2100
10900	0	0	0	0	0	0
10900	100	0	200	1	1	1
10900	544	77	155	0	209	116
101000	0	0	0	0	0	0
101100	0	0	0	0	0	0
101300	0	0	0	0	0	0
101400	0	0	0	0	0	0
200000	1187	739	2268	443	592	740
300000	19096	4590	2997	10876	2899	11902
310000	10697	2000	652	2603	1072	7325

	1314	1793	1363
900000	0	0	0
909100	0	0	0
909120	0	0	0
909190	0	0	0
909200	0	0	0
909300	0	0	0

INDUSTRIAL EMPLOYMENT CALENDAR CHANGE RATIOS

NEW	JERSEY	NEWARK	PATERSON ET. AL.	HUDSON	MENCFR	CAMDEN LMA	P. AMBOY ET. AL.	ATLANTIC	MONMOUTH	CAPE MAY	
											10000
1.018495	1.011826	1.019400	0.996427	1.026911	1.035779	1.021333	1.108294	0.995151	1.168673		
1.243636	1.398299	1.309091	2.059405	1.501984	1.350126	1.282172	1.412210	1.188773	1.129574		
1.247263	1.399180	1.303941	2.101009	1.503973	1.318352	1.253731	1.432620	1.189260	1.120000		
1.243636	1.398299	1.303091	2.059405	1.501984	1.350126	1.282172	1.412210	1.188778	1.129674		
1.000000	1.398299	1.309091	2.059405	1.501984	1.350126	1.282172	1.330000	1.103778	1.000000		
1.040737	1.159712	1.003105	0.996427	1.038960	0.459770	1.040515	0.640000	0.459770	1.668965		
1.061547	1.154727	1.003105	0.996427	1.038960	0.459770	1.040515	0.640000	0.459770	1.668965		
1.040737	1.159712	1.003105	0.996427	1.038960	0.459770	1.040515	0.640000	0.459770	1.668965		
1.040737	1.159712	1.003105	0.996427	1.038960	0.459770	1.040515	0.640000	0.459770	1.668965		
1.037566	1.171511	1.009375	0.996427	1.066667	0.444444	1.030000	0.650406	0.465116	1.668965		
1.078913	1.118325	1.078369	1.074280	1.034793	1.163049	1.122900	0.993039	1.083164	0.948518		
1.00135	1.000123	1.005171	0.988495	0.979420	1.015648	1.001731	1.014546	0.976819	1.064334		
0.995389	0.994385	1.006103	0.982367	0.972656	1.009579	1.002316	0.965928	0.974356	1.094202		

1.004339	1.002710	1.004755	1.007253	1.004586	1.024757	1.000798	1.759299	0.998441	1.047194	
0.988661	0.987841	0.923535	0.995079	0.994509	1.025209	0.979310	1.146428	0.992220	1.047194	
0.986724	1.040241	0.922130	0.939611	1.000000	1.025640	0.979592	1.148854	0.993076	1.047194	
0.988657	0.962941	0.622222	1.040123	0.987991	1.025529	0.979416	1.145869	0.992234	1.047194	
1.016801	1.016614	1.056319	1.006633	1.002906	1.017698	0.988217	1.020325	1.013248	1.047194	
1.015369	1.010788	1.028210	1.011764	1.014828	1.017488	1.028684	1.019140	1.013036	1.047194	

INDUSTRIAL EMPLOYMENT CALENDAR CHANGE RATIOS

NUMBER	HUNTER -DON	OCEAN	SALEM	SUSSEX	WARREN	10000	10100	10800	10900	100000	101000	101100	101300	101400	200000	300000	310000	
																		0
1.053292	0.986654	1.006238	1.031681	1.055250	0.998505													
1.313803	1.016609	0.954992	1.167608	1.037715	1.092745													
1.294117	1.037037	0.967033	1.142857	1.018182	1.067767													
1.313803	1.016609	0.954992	1.167608	1.037715	1.092745													
1.000000	1.016609	1.000000	1.167608	1.037715	1.092745													
1.078094	1.000000	1.362068	1.031681	1.142179	1.043103													
1.078094	1.000000	1.362068	1.031681	1.142179	1.043103													
1.078094	1.000000	1.362068	1.031681	1.142179	1.043103													
1.078094	1.000000	1.362068	1.031681	1.142179	1.043103													
1.115475	1.209215	1.031574	1.088362	1.189784	1.041078													
1.040647	0.945295	0.951570	1.034142	1.002420	0.955732													
1.028911	0.919136	0.940094	1.038299	1.076652	0.915001													

0.986738	0.962344	1.007596	0.899611	1.020953	1.058113													
0.986738	0.962344	1.007596	0.899611	1.020953	1.058113													
0.986738	0.962344	1.007596	0.899611	1.020953	1.058113													
0.986738	0.962344	1.007596	0.899611	1.020953	1.058113													
0.986738	0.962344	1.007596	0.899611	1.020953	1.058113													

REPORT NUMBER 12

NATIONAL RATIOS OF INDUSTRIAL TOTAL TO WAGE AND SALARY 1960 TO 1975 TREND FACTOR

	JERSEY NEW
0	1.026354
10000	1.016582
10100	1.000000
10500	1.193180
10900	1.475414
100000	1.016044
101000	0.997204
101100	1.000900
101300	1.024404
101300	1.017907
101400	0.960499
200000	1.015042
300000	1.013777
310000	1.018767
312400	

900000	0.941663
909100	1.054204
909120	1.004529
909190	1.063326
909200	1.217901
909300	1.041274

Output Reports - Algorithm D

Output reports 1 and 2 are of identical formats for years 1960 and 1975 respectively. We reproduce portions of report 1 to depict the format.

Output reports 3 through 12 have similar formats, (differing only in the number of areas). We display portions of data set 3, which is in three parts, with different areas in each part.

Output reports 13 through 17 also have formats differing only in the number of areas. We display portions of report 13. This report is labeled report 5 since we only requested five reports from this algorithm, not the full set.

Algorithm D

<u>Number</u>	<u>Title</u>	<u>Based on Industry Level *</u>	<u>Area</u>	<u>Results from Step</u>	<u>Industry or Occupational Level **</u>
1	Expanded 1960 Total Industrial Employment	N.A.	III & IVG	6	III A, IV, or V
2	Expanded 1975 Total Industrial Employment	N.A.	III & IVG	5	III A, IV, or V
3	1960 Occupational Employment	II	III & IVG	16	IVO
4	1960 Occupational Employment	III	III & IVG	17	IVO
5	1960 Occupational Employment	III A	III & IVG	17	IVO
6	1960 Occupational Employment	IV	A	18	IVO
7	1960 Occupational Employment	V	B	19	IVO
8	1975 Occupational Employment	II	III & IVG	16	IVO
9	1975 Occupational Employment	III	III & IVG	17	IVO
10	1975 Occupational Employment	III A	III & IVG	17	IVO
11	1975 Occupational Employment	IV	A	18	IVO
12	1975 Occupational Employment	V	B	19	IVO
13	Occupational Change Factors	II	III & IVG	16	IVO
14	Occupational Change Factors	III	III & IVG	17	IVO
15	Occupational Change Factors	III A	III & IVG	17	IVO
16	Occupational Change Factors	IV	A	18	IVO
17	Occupational Change Factors	V	B	19	IVO

*Occupational employments and change factors may be calculated for any of levels II through V industry structures. Since industry data is not available at all levels, results are valid only in the combinations of areas and industry level as indicated below.

"A" includes III and IVG except Cape May, Cumberland, Hunterdon, Ocean, Salem, Sussex, and Warren.
 "B" includes "A" except Essex, Morris, Union, Bergen, Passaic, Burlington, Camden, Gloucester, Middlesex and Somerset.

III and IVG include the state, all four LMA's, and all 21 counties.

** For areas Cape May, Cumberland, Hunterdon, Ocean, Salem, Sussex, and Warren, industry data is valid only to level IIIA.

For areas Essex, Morris, Union, Bergen, Passaic, Burlington, Camden, Gloucester, Middlesex, and Somerset industry data is valid only to level IV.

REPORT NUMBER 1

EXPANDED 1960 TOTAL INDUSTRIAL EMPLOYMENT

	ESSEX	MORRIS	UNION	BERGEN	PASSAIC	CAMDEN CO.	MIDDLE -SEX	BURLING -TON	GLOUCES -TER	SOMER -SET
0	415129	72881	198431	233193	163422	142686	133534	43694	24867	35050
10000	1601	1343	2233	2514	822	3248	3089	2933	1734	681
10100	1601	1343	2233	2514	822	3248	3089	2933	1734	681
10300	0	0	0	0	0	0	0	0	0	0
10360	0	0	0	0	0	0	0	0	0	0
10700	0	0	0	0	0	0	0	0	0	0
100000	86	881	115	69	435	20	58	6	7	69
101000	0	584	0	0	0	0	0	0	0	0
101100	0	0	0	0	0	0	0	0	0	0
101300	0	0	0	0	0	0	0	0	0	0
101400	0	0	0	0	0	0	0	0	0	0
200000	86	297	115	69	435	20	58	6	7	69
300000	19785	4425	13004	18326	7908	10328	10265	6169	2832	3665
310000	147028	24230	93968	89417	81483	69668	72646	18893	12643	15801
312400	86457	11667	54583	47647	29601	39103	36684	10967	2860	8823
	690	331	370	373	276	233	454	204	92	61

900000	14432	8101	5309	7435	5034	1841	5107	3262	438	1657
909100	4682	5366	1575	3242	2126	607	3210	2646	102	802
909120	0	0	0	0	0	0	0	0	0	0
909190	0	0	0	0	0	0	0	0	0	0
909200	1133	782	144	217	866	194	250	88	28	350
909300	8617	1953	3570	3976	2042	1040	1647	528	308	505

REPORT NUMBER 3

1960 OCCUPATIONAL EMPLOYMENT

	NEW JERSEY	NEWARK	PATERSON ET AL.	HUDSON	MERCER	CAMDEN LMA	P. AMBY ATLANTIC	MONMOUTH	CAPE MAY
0	225716.	693651.	401414.	253309.	122547.	242967.	193713.	92077.	17361.
1000	249779.	79157.	43637.	26035.	16511.	25898.	21242.	8336.	2111.
	34086.	10416.	6441.	4251.	1792.	3935.	3317.	597.	171.
	1110.	672.	424.	283.	107.	255.	221.	25.	7.
	1120.	555.	351.	229.	86.	208.	181.	22.	6.
	1130.	5094.	877.	471.	335.	610.	454.	165.	55.
	1140.	7590.	1427.	1046.	381.	856.	730.	123.	33.
7999									
8000	64945.	21291.	11281.	6197.	4320.	6357.	5039.	2669.	3182.
9000	132000.	39757.	24291.	15736.	6992.	15036.	11904.	3362.	5295.
7100	41451.	4793.	3088.	383.	2028.	7456.	3534.	2602.	3952.
	58325.	19063.	9838.	5021.	4415.	5599.	4536.	2582.	3103.

1960 OCCUPATIONAL EMPLOYMENT

	CUMBERLAND	HUNTERDON	OCEAN	SALEM	SUSSEX	WARREN	ESSEX	MORRIS	UNION	BERGEN
0	37337.	16508.	28303.	23598.	15581.	23872.	415129.	72881.	198431.	233193.
1000	3805.	1770.	3185.	2282.	1603.	2450.	48085.	9295.	20646.	25549.
	477.	222.	317.	410.	192.	391.	5906.	1106.	3379.	3562.
	1110.	13.	12.	29.	9.	25.	374.	68.	230.	224.
	1120.	25.	9.	24.	9.	22.	310.	55.	190.	186.
	1130.	80.	126.	48.	46.	49.	806.	191.	425.	568.
	1140.	102.	53.	91.	37.	87.	1362.	233.	747.	779.
7950										
7999										
8000	107.	50.	94.	50.	45.	60.	1377.	261.	489.	683.
9000	1042.	455.	927.	495.	435.	585.	13452.	2331.	5057.	6822.
7100	2055.	964.	1854.	1435.	891.	1426.	23360.	4002.	12140.	14369.
	4306.	2105.	1231.	1986.	1773.	1547.	1482.	1243.	2067.	2327.
	936.	441.	821.	432.	393.	524.	12084.	2265.	4276.	5991.

1960 OCCUPATIONAL EMPLOYMENT

	PASSAIC	CAMDEN CO	MIDDLESEX	BURLINGTON	GLUCCES	SOMERSET
0	163422.	122686.	133534.	43694.	24867.	35050.
1000	17391.	11916.	12847.	4141.	2115.	4225.
	2853.	2376.	2556.	785.	458.	609.
	200.	167.	178.	49.	30.	40.
	165.	138.	144.	38.	25.	33.
	307.	273.	323.	165.	73.	95.
	645.	516.	564.	159.	97.	129.
7999						
8000	4172.	2458.	2606.	796.	415.	997.
9000	9749.	8058.	8745.	3085.	1727.	2162.
7100	761.	3007.	2860.	2715.	1605.	620.
	3579.	2045.	2070.	658.	303.	991.

OCCUPATIONAL CHANGE FACTORS

	NEW JERSEY	NEWARK	PATERSON ET AL.	HUDSON	MERCER	CAMDEN LMA	P. AMBOY ET AL.	ATLANTIC	MONMOUTH	C.I.P.E. M.A.
0	1.412651	1.303887	1.507321	1.046630	1.310207	1.421522	1.862121	1.444215	1.744431	1.477967
1000	1.854573	1.721641	1.658031	1.438371	1.864432	1.937753	2.523359	1.757703	2.436689	1.974243
1100	1.768414	1.669753	1.950665	1.334379	1.582257	1.578358	2.286787	2.054442	2.247955	1.737714
	1.346358	1.251168	1.459579	0.922723	1.366805	1.193249	1.634087	2.050354	2.136705	1.595621
1110	1.544396	1.441420	1.765181	1.187640	1.394779	1.286764	2.010752	2.015430	2.119457	1.341908
1120	1.721684	1.637594	1.745625	1.320004	1.271504	1.762036	2.311969	1.533043	1.876427	1.765437
1130	1.802264	1.731797	2.004118	1.337111	1.697669	1.580737	2.378621	2.136150	2.367203	1.666328
1140	1.991665	1.862427	2.268563	1.520767	1.814763	1.670535	2.581209	2.583249	2.706529	1.827072
1150										
7999	1.570666	1.405722	1.323693	1.205809	1.648858	1.790609	2.283268	1.419041	2.127001	1.703120
8000	1.008423	0.945577	1.105732	0.745008	0.827884	0.983556	1.238148	1.054331	1.219240	1.098541
9000	0.630309	0.454241	0.637539	0.634175	0.711655	0.617378	1.152008	0.956850	0.283171	0.743451
7100	1.296841	1.188093	0.903630	1.076283	1.382048	1.475977	1.938179	1.114302	1.796414	1.430221

OCCUPATIONAL CHANGE FACTORS

	CUMBERLAND	HUNTER-DUN	OCEAN	SALEM	SUSSEX	KARREN	ESSEX	MURRIS	UNION	BERGEN
0	1.416155	1.546341	2.108327	1.226079	1.563057	1.395987	1.046828	2.050369	1.568791	1.674767
1000	2.145873	2.448419	2.722178	1.816124	2.467189	2.136227	1.390230	2.639650	2.085870	1.823750
1100	1.781300	2.178649	2.710683	1.579834	1.833396	1.787483	1.312903	2.767052	1.928451	2.115663
	1.343144	1.878475	2.603746	1.084453	1.502848	1.322689	0.959400	2.379411	1.386794	1.524595
111C	1.488188	2.068050	2.287735	1.339627	1.534665	1.615388	1.090194	2.664068	1.661657	1.951155
112C	1.761580	1.521619	2.823451	2.050961	1.593940	1.392226	1.459043	1.910315	1.852371	1.648314
1130	1.851238	2.305499	2.585238	1.514629	2.026337	1.855762	1.338136	3.020520	2.041382	2.222521
1140	1.967169	2.660857	2.926225	1.721514	2.060421	2.103392	1.418391	3.441476	2.148510	2.517457
1150	1.614392	2.146608	2.301346	1.427202	1.667936	1.725893	1.171201	2.762613	1.782896	2.050369
7999	1.848562	2.116481	2.333611	1.600319	2.272346	1.930389	1.131457	2.242673	1.757710	1.515537
8000	1.034184	0.994629	1.725736	0.897880	1.097030	0.896372	0.775534	1.433539	1.110518	1.202187
9000	0.789690	0.467641	0.101543	0.824459	0.378754	0.453276	0.471325	0.558640	0.499066	0.606322
7100	1.631918	1.799054	1.936106	1.417507	1.996401	1.702332	0.973241	1.818765	1.471944	1.030138

OCCUPATIONAL CHANGE FACTORS

	PASSAIC	CAMDEN	MIDDLESEX	BURLINGHAM	GLOUCESTER	SOMERSET
0	1.274871	1.118138	1.696115	1.626378	1.467065	1.993438
1000	1.438390	1.476285	2.414842	2.380363	2.060390	2.264709
1100	1.746407	1.288904	2.141880	1.816615	1.881034	2.587677
	1.273294	0.860081	1.500395	1.435960	1.525681	1.915384
1110	1.545727	1.044417	1.902929	1.679453	1.643512	2.312106
1120	1.931569	1.813007	2.185638	1.502312	1.781125	2.685273
1130	1.741317	1.251472	2.171260	1.907478	1.912978	2.564756
1140	1.986670	1.351455	2.434589	2.149307	2.129290	2.944444
1150						
7999	1.029689	1.350116	2.156525	2.548096	1.695457	1.839307
8000	0.961561	0.822076	1.179347	1.029878	0.982534	1.467630
9000	0.733016	0.707442	0.842303	0.787606	0.331146	2.467139
7100	0.709900	1.100488	1.953723	2.221319	1.298942	1.331054

Output Reports - Algorithm E

All reports for algorithm E are of identical format. We display selected portions of report 1, which contains New Jersey totals of the April 1, 1960 census occupational employment matrix.

Number	Title	Area	Result from Step	Occupational Level
1	April 1, 1960, Census Occupational Employment	New Jersey	16	IVO & IIOS
2	April 1, 1960, Census Occupational Employment	Newark	16	IVO & IIOS
3	April 1, 1960, Census Occupational Employment	Paterson, et al	16	IVO & IIOS
4	April 1, 1960, Census Occupational Employment	Hudson	16	IVO & IIOS
5	April 1, 1960, Census Occupational Employment	Mercer	16	IVO & IIOS
6	April 1, 1960, Census Occupational Employment	Atlantic	16	IVO & IIOS
7	April 1, 1960, Census Occupational Employment	Monmouth	16	IVO & IIOS
8	April 1, 1960, Census Occupational Employment	Essex	16	IVO & IIOS
9	April 1, 1960, Census Occupational Employment	Morris	16	IVO & IIOS
10	April 1, 1960, Census Occupational Employment	Union	16	IVO & IIOS
11	April 1, 1960, Census Occupational Employment	Bergen	16	IVO & IIOS
12	April 1, 1960, Census Occupational Employment	Passaic	16	IVO & IIOS
13	April 1, 1960, Census Occupational Employment	Camden	16	IVO & IIOS
14	April 1, 1960, Census Occupational Employment	Middlesex	16	IVO & IIOS
15	April 1, 1960, Census Occupational Employment	Cape May	16	IVO & IIOS
16	April 1, 1960, Census Occupational Employment	Cumberland	16	IVO & IIOS
17	April 1, 1960, Census Occupational Employment	Hunterdon	16	IVO & IIOS
18	April 1, 1960, Census Occupational Employment	Ocean	16	IVO & IIOS
19	April 1, 1960, Census Occupational Employment	Salem	16	IVO & IIOS
20	April 1, 1960, Census Occupational Employment	Sussex	16	IVO & IIOS
21	April 1, 1960, Census Occupational Employment	Warren	16	IVO & IIOS
22	April 1, 1960, Census Occupational Employment	Burlington	16	IVO & IIOS
23	April 1, 1960, Census Occupational Employment	Gloucester	16	IVO & IIOS
24	April 1, 1960, Census Occupational Employment	Somerset	16	IVO & IIOS

REPORT NUMBER 1

APRIL 1, 1960, CENSUS OCCUPATIONAL EMPLOYMENT

NEW	
JERSEY	
2345444	
307901	
49102	
1475	
4154	
5627	
14608	
5038	
8796	
752	
96	
8560	
49435	

0		
1000		
1100		
1110		
1120		
1130		
1140		
1150		
1160		
1170		
1180		
1199		
1200		
.		
.		
.		
7920		12009
7930		6483
7940		14889
7950		5186
7999		46769
8000		98270
9000		27826
9010		14670
9020		13156
7100		41048
999		0



Output Reports - Algorithm F

There are twenty-four reports produced by algorithm F. Report number one, which we display in its entirety, contains the April 1, 1960 commutation matrix, by occupation.

Reports 2-24 all are in the same format. They contain April 1, 1960 total occupational employment data for different areas. We display report number 2, for Newark, as representative of these reports.

Algorithm F

<u>Number</u>	<u>Title</u>	<u>Areas</u>	<u>Result from Step</u>	<u>Occupation Level</u>
1	April 1, 1960, Net Commutation By Occupation	VG	11	IIOS
2	April 1, 1960, Total Occupational Employment (Establishment Basis) Newark	(Establishment Basis) Newark	29	IVO
3	April 1, 1960, Total Occupational Employment (Establishment Basis) Paterson, et al	(Establishment Basis) Paterson, et al	29	IVO
4	April 1, 1960, Total Occupational Employment (Establishment Basis) Hudson	(Establishment Basis) Hudson	29	IVO
5	April 1, 1960, Total Occupational Employment (Establishment Basis) Mercer	(Establishment Basis) Mercer	29	IVO
6	April 1, 1960, Total Occupational Employment (Establishment Basis) Atlantic	(Establishment Basis) Atlantic	29	IVO
7	April 1, 1960, Total Occupational Employment (Establishment Basis) Monmouth	(Establishment Basis) Monmouth	29	IVO
8	April 1, 1960, Total Occupational Employment (Establishment Basis) Essex	(Establishment Basis) Essex	29	IVO
9	April 1, 1960, Total Occupational Employment (Establishment Basis) Morris	(Establishment Basis) Morris	29	IVO
10	April 1, 1960, Total Occupational Employment (Establishment Basis) Union	(Establishment Basis) Union	29	IVO
11	April 1, 1960, Total Occupational Employment (Establishment Basis) Bergen	(Establishment Basis) Bergen	29	IVO
12	April 1, 1960, Total Occupational Employment (Establishment Basis) Passaic	(Establishment Basis) Passaic	29	IVO
13	April 1, 1960, Total Occupational Employment (Establishment Basis) Camden Co.	(Establishment Basis) Camden Co.	29	IVO
14	April 1, 1960, Total Occupational Employment (Establishment Basis) Middlesex	(Establishment Basis) Middlesex	29	IVO
15	April 1, 1960, Total Occupational Employment (Establishment Basis) Cape May	(Establishment Basis) Cape May	29	IVO
16	April 1, 1960, Total Occupational Employment (Establishment Basis) Cumberland	(Establishment Basis) Cumberland	29	IVO
17	April 1, 1960, Total Occupational Employment (Establishment Basis) Hunterdon	(Establishment Basis) Hunterdon	29	IVO
18	April 1, 1960, Total Occupational Employment (Establishment Basis) Ocean	(Establishment Basis) Ocean	29	IVO
19	April 1, 1960, Total Occupational Employment (Establishment Basis) Salem	(Establishment Basis) Salem	29	IVO
20	April 1, 1960, Total Occupational Employment (Establishment Basis) Sussex	(Establishment Basis) Sussex	29	IVO
21	April 1, 1960, Total Occupational Employment (Establishment Basis) Warren	(Establishment Basis) Warren	29	IVO
22	April 1, 1960, Total Occupational Employment (Establishment Basis) Burlington	(Establishment Basis) Burlington	29	IVO
23	April 1, 1960, Total Occupational Employment (Establishment Basis) Gloucester	(Establishment Basis) Gloucester	29	IVO
24	April 1, 1960, Total Occupational Employment (Establishment Basis) Somerset	(Establishment Basis) Somerset	29	IVO

Area VG includes all 21 counties plus Pennsylvania, New York, Delaware, and "Elsewhere".

APRIL 1, 1960, NET COMMUTATION BY OCCUPATION:

	ATLANTIC	BERGEN	BURLING -TON	CAMDEN CO	CAPE MAY	CUMBER -LAND	ESSEX	GLOUCESTER -TER	HUDSON	HUNTER -DON
G	-5278	-78952	-992	-20577	-859	2145	27105	-15564	1632	-5205
1000	-742	-13405	-789	-4957	-202	309	2153	-2965	-3046	-932
290	-435	-14143	-873	-4549	-124	92	519	-1996	182	-687
4000	-370	-7132	-544	-2905	-113	69	3634	-1398	-1295	-412
5000	-449	-26488	-1222	-6271	-71	263	12883	-2923	-8449	-820
6000	-1248	-10478	325	-2979	-149	540	5231	-2969	4725	-985
7000	-1369	-4260	1024	-697	-124	625	2375	-2535	9748	-910
890	-41	579	288	854	-2	15	-546	8	-104	-24
	-242	-3308	280	266	-36	76	1099	-457	-1416	-203
	-377	-313	518	662	-34	152	-305	-325	1790	-228

APRIL 1, 1960, NET COMMUTATION BY OCCUPATION:

	MERCER	MIDDLE -SEX	MONMOUTH	MORRIS	OCEAN	PASSAIC	SALEM	SUMNER -SET	SUSSEX	UNION
J	10620	-28209	-25239	-12922	-7541	817	360	-10336	-4307	-8647
1000	2063	-4732	-5211	-2530	-1494	230	17	-1808	-673	-1770
290	1177	-3429	-4987	-3386	-1427	390	-39	-1058	-379	-5823
4000	1041	-2306	-2467	-1750	-715	126	-70	-774	-257	-2531
5000	2343	-5610	-3694	-2520	-1039	-358	-67	-1887	-646	-3538
6000	2078	-5165	-3964	-1346	-1277	890	130	-2084	-951	1007
7000	1397	-5267	-3410	-952	-1085	189	241	-2081	-1076	2777
890	30	-58	-135	13	-36	-296	24	-41	-21	309
	416	-887	-725	-324	-230	-46	34	-360	-147	248
	49	-753	-642	-174	-234	-308	88	-299	-154	674

APRIL 1, 1960, NET COMMUTATION BY OCCUPATION:

	WAKEN	PENNSYLVANIA	NEW YORK	DELAWARE	ELSE -WHERE
G	-1213	31618	128621	84	22703
1000	-100	5836	27842	36	5853
290	-106	6235	29033	34	5783
4000	-191	4118	13148	49	2941
5000	-256	3563	38499	113	3649
6000	-136	5090	11390	27	2299
7000	-206	2632	2075	-52	1241
890	-20	-1132	273	-30	93
	5	-179	5588	-54	606
	98	-547	770	-40	234

REPORT NUMBER 2

APRIL 1, 1990, TOTAL OCCUPATIONAL EMPLOYMENT (ESTABLISHMENT BASIS)
NEWARK

1000	68666
1100	96556
1110	17158
1120	437
1130	1411
1140	1724
1150	5177
1160	1553
1170	3681
1180	309
1190	40
1200	2927
1210	232
1220	1160
1230	
1240	
1250	
1260	
1270	
1280	
1290	
1300	
1310	
1320	
1330	
1340	
1350	
1360	
1370	
1380	
1390	
1400	
1410	1483
1420	3523
1430	1896
1440	3939
1450	1694
1460	13977
1470	27596
1480	1105
1490	26491
1500	
1510	
1520	
1530	
1540	
1550	
1560	
1570	
1580	
1590	
1600	
1610	
1620	
1630	
1640	
1650	
1660	
1670	
1680	
1690	
1700	
1710	
1720	
1730	
1740	
1750	
1760	
1770	
1780	
1790	
1800	
1810	
1820	
1830	
1840	
1850	
1860	
1870	
1880	
1890	
1900	
1910	
1920	
1930	
1940	
1950	
1960	
1970	
1980	
1990	
2000	

Output Reports - Algorithm G

The reports for algorithm G all have similar formats since they are all for the same set of areas. The number of areas requires that each report be in three parts. We display portions of reports one, six (labeled as two), ten (labeled as three), sixteen (labeled as four), twenty-one (labeled as five), and twenty-six (labeled as six).

Note: the disparity in labeling is a result of our not requesting all possible reports when running the algorithm.

Algorithm G

Number	Title	Based on		Results from	
		Industry* Level	Area	Algorithm Step	Occupational Level
1	1975 Total Occupational Employment (Establishment Basis)	1	State & IVG	1	IO-IVO
2	1975 Total Occupational Employment (Establishment Basis)	2	State & IVG	1	IO-IVO
3	1975 Total Occupational Employment (Establishment Basis)	3	State & IVG	1	IO-IVO
4	1975 Total Occupational Employment (Establishment Basis)	4	State & IVG	1	IO-IVO
5	1975 Total Occupational Employment (Establishment Basis)	5	State & IVG	1	IO-IVO
6	1975 Total Occupational Employment (Establishment Basis) -Prorated	1	State & IVG	3	IO-IVO
7	1975 Total Occupational Employment (Establishment Basis) -Prorated	2	State & IVG	3	IO-IVO
8	1975 Total Occupational Employment (Establishment Basis) -Prorated	3	State & IVG	3	IO-IVO
9	1975 Total Occupational Employment (Establishment Basis) -Prorated	4	State & IVG	3	IO-IVO
10	1975 Total Occupational Employment (Establishment Basis) -Prorated	5	State & IVG	3	IO-IVO
11	1973 Total Occupational Employment (Establishment Basis)	1	State & IVG	4	IO-IVO
12	1973 Total Occupational Employment (Establishment Basis)	2	State & IVG	4	IO-IVO
13	1973 Total Occupational Employment (Establishment Basis)	3	State & IVG	4	IO-IVO
14	1973 Total Occupational Employment (Establishment Basis)	4	State & IVG	4	IO-IVO
15	1973 Total Occupational Employment (Establishment Basis)	5	State & IVG	4	IO-IVO
16	Annual Openings Due to Growth of Economy	1	State & IVG	6	IO-IVO
17	Annual Openings Due to Growth of Economy	2	State & IVG	6	IO-IVO
18	Annual Openings Due to Growth of Economy	3	State & IVG	6	IO-IVO
19	Annual Openings Due to Growth of Economy	4	State & IVG	6	IO-IVO
20	Annual Openings Due to Growth of Economy	5	State & IVG	6	IO-IVO
21	Annual Openings Due to Replacement Demand	1	State & IVG	6	IO-IVO
22	Annual Openings Due to Replacement Demand	2	State & IVG	6	IO-IVO
23	Annual Openings Due to Replacement Demand	3	State & IVG	6	IO-IVO
24	Annual Openings Due to Replacement Demand	4	State & IVG	6	IO-IVO
25	Annual Openings Due to Replacement Demand	5	State & IVG	6	IO-IVO
26	Total Annual Openings	1	State & IVG	6	IO-IVO
27	Total Annual Openings	2	State & IVG	6	IO-IVO
28	Total Annual Openings	3	State & IVG	6	IO-IVO
29	Total Annual Openings	4	State & IVG	6	IO-IVO
30	Total Annual Openings	5	State & IVG	6	IO-IVO

*Occupational change factors are calculated for each industry level selected in algorithm D and are used in generating the results listed here.

1975 TOTAL OCCUPATIONAL EMPLOYMENT (ESTABLISHMENT BASIS)

	NEW JERSEY	ATLANTIC	BERGEN	BURLING -TON	CAMDEN CO	CAPE MAY	CUMBER -LAND	ESSEX	GLOUCESTER	HUDSON
C	3087049	77806	389119	112402	143426	22508	66232	420317	52309	266278
1000	501451	6990	65051	18676	19609	2361	7320	70087	5503	33577
1100	76335	602	13885	3224	3560	127	516	9024	837	2263
1110	215	0	0	76	0	3	11	0	20	0
1120	709	0	0	252	0	8	36	0	61	0
1130	1078	0	0	306	0	14	60	0	91	0
8000	100347	2521	9367	3564	5153	1099	2549	12602	2078	12050
9000	16177	1415	507	1722	399	213	2570	286	571	113
7100	55867	1521	5569	3585	3568	672	1196	8984	1118	1608

1975 TOTAL OCCUPATIONAL EMPLOYMENT (ESTABLISHMENT BASIS)

	HUNTER -DON	MERCER	MIDDLE -SEX	MONMOUTH	MORRIS	OCEAN	PASSAIC	SALEM	SOMER -SET	SUSSEX
0	25584	156475	230248	155933	170976	60789	210972	28858	97049	23587
1000	3146	32346	38925	29460	44758	6599	26721	4045	16883	4419
1100	377	2848	4839	5294	11231	930	4673	455	4063	444
1110	9	0	0	0	0	26	0	10	88	11
1120	31	0	0	0	0	66	0	32	308	31
1130	30	0	0	0	0	110	0	68	483	45
8000	934	4399	8340	5448	4454	2960	5857	948	3101	1006
9000	805	845	885	606	293	79	342	1517	2294	587
7100	941	3584	3042	5810	3019	1208	1276	816	1573	547

1975 TOTAL OCCUPATIONAL EMPLOYMENT (ESTABLISHMENT BASIS)

	UNION	WARREN
0	31017	34185
1000	63050	4433
1100	12313	440
1110	0	9
1120	0	34
1130	0	41
8000	8209	1264
9000	228	728
7100	6069	582

REPORT NUMBER 2

ALGORITHM G

1975 TOTAL OCCUPATIONAL EMPLOYMENT (ESTABLISHMENT BASIS) - PRORATED

	NEW JERSEY	ATLANTIC	BERGEN	BURLINGAME	CAMDEN	CAPE MAY	CUMBERLAND	ESSEX	GLoucester	HUDSON
0	3087049	78618	393179	113575	144923	22743	66923	424703	52855	269056
1000	498864	7096	64544	17748	19033	2418	7577	69810	5452	33943
1100	76335	557	10975	2893	2775	119	621	10037	451	2579
1110	215	62	1219	66	308	3	13	1115	11	287
1120	709	62	1219	219	308	8	42	1115	33	287
8000	99829	2629	9544	3478	5136	1156	2709	12891	2114	12509
9000	16094	1359	476	1549	367	207	2518	270	535	108
7100	55579	1534	5493	3386	3442	684	1231	8894	1101	1817

1975 TOTAL OCCUPATIONAL EMPLOYMENT (ESTABLISHMENT BASIS) - PRORATED

	HUNTERDON	MERCER	MIDDLESEX	MONMOUTH	MORRIS	OCEAN	PASSAIC	SALEM	SOMERSET	SUSSEX
0	25851	158108	232650	157560	172760	61423	213173	29159	98062	23833
1000	3173	32458	38106	29281	43816	6591	26605	4059	16826	4426
1100	240	3382	3949	4121	10335	639	5110	486	3543	353
1110	5	374	439	458	1148	18	568	11	76	8
1120	19	374	439	458	1148	46	568	34	267	24
8000	967	4534	8384	5560	4478	3036	5988	977	3173	1034
9000	768	803	820	570	272	75	322	1442	2164	557
7100	943	3575	2960	5740	2937	1200	1262	813	1558	544

1975 TOTAL OCCUPATIONAL EMPLOYMENT (ESTABLISHMENT BASIS) - PRORATED

	UNION	WARREN
0	313353	34542
1000	61376	4524
1100	12217	448
1110	1357	9
1120	1357	34
8000	8206	1325
9000	210	703
7100	5871	591

1973 TOTAL OCCUPATIONAL EMPLOYMENT (ESTABLISHMENT BASIS)

	JERSEY	NEW JERSEY	ATLANTIC	BERGEN	BURLINGAME	CAMDEN	CAPE MAY	CUMBERLAND	ESSEX	GLOUCESTER	HUDSON
0	2966813	75319	371734	107647	142703	21741	64236	421611	50562	267104	
1000	468400	6680	60694	16428	18266	2255	7022	67224	5081	32530	
1100	71912	522	10387	2744	2773	113	577	9615	450	2461	
1110	208	54	1056	64	267	3	12	966	11	249	
1120	676	54	1056	250	267	8	40	966	34	249	
8000	99786	2597	9310	3476	5287	1135	2676	13339	2114	12998	
9000	17370	1375	524	1634	393	218	2616	315	694	117	
7100	53912	1511	5481	3150	3415	655	1165	8939	1069	1799	

1973 TOTAL OCCUPATIONAL EMPLOYMENT (ESTABLISHMENT BASIS)

	HUNTERDON	MERCER	MIDDLESEX	MONMOUTH	MORRIS	OCEAN	PASSAIC	SALEM	SOMERSET	SUSSEX
0	24610	152951	219730	148470	160844	57078	206815	28384	91478	22667
1000	2921	30443	35174	26989	40235	6035	25535	3815	15577	4075
1100	231	3154	3724	3886	9498	600	4785	460	3260	338
1110	5	324	380	397	995	17	492	11	72	6
1120	18	324	380	397	995	44	492	33	249	23
8000	963	4638	8209	5414	4295	2860	6002	988	3032	1018
9000	895	854	851	779	345	169	341	1496	1999	689
7100	887	3444	2772	5406	2767	1123	1333	781	1508	508

1973 TOTAL OCCUPATIONAL EMPLOYMENT (ESTABLISHMENT BASIS)

	UNION	WARREN
0	297930	33201
1000	57223	4197
1100	11439	421
1110	1176	9
1120	1176	32
8000	8097	1336
9000	243	824
7100	5636	558



REPORT NUMBER 4

ALGORITHM G

ANNUAL OPENINGS DUE TO GROWTH OF ECONOMY

	NEW JERSEY	ATLANTIC	BERGEN	BURLING -TON	CAMDEN CO	CAPE MAY	CUMBER -LAND	ESSEX	GLOUCHES -TER	HUDSON
0	50117	1650	10722	2964	1110	501	1344	1546	1147	976
1000	15232	208	1925	660	383	81	278	1293	185	707
1100	2211	18	294	75	1	3	22	211	0	59
1110	4	4	81	1	21	0	0	74	0	19
1120	17	4	81	5	21	0	1	74	0	19
8000	21	16	117	1	-75	10	16	-224	0	-244
9000	-638	-8	-24	-43	-13	-5	-49	-22	-79	-5
7100	833	11	6	113	13	14	33	-22	16	9

ANNUAL OPENINGS DUE TO GROWTH OF ECONOMY

	HUNTER -DON	MERCER	MIDDLE -SEX	MONMOUTH	MORRIS	OCEAN	PASSAIC	SALEM	SOMER -SET	SUSSEX
0	620	2579	6460	4545	5958	2173	3179	388	3292	583
1000	126	1007	1466	1146	1791	278	535	122	625	176
1100	4	104	113	118	418	20	162	13	132	7
1110	0	23	29	31	77	1	38	0	2	0
1120	0	25	29	31	77	1	38	1	9	0
1130	0	25	29	31	77	3	38	3	16	0
8000	2	-52	87	73	91	88	-7	-5	71	8
9000	-64	-26	-15	-105	-36	-47	-10	-27	82	-66
7100	28	65	94	167	85	38	-36	16	25	18

D.34

ANNUAL OPENINGS DUE TO GROWTH OF ECONOMY

	UNION	WARREN
0	7712	670
1000	2077	163
1100	389	13
1110	90	0
1120	90	1
1130	90	1
8000	54	-6
9000	-16	-60
7100	117	17

ALPHABET NUMBER 5

ANNUAL OPENINGS DUE TO REPLACEMENT DEMAND

	NEW JERSEY	ATLANTIC	BERGEN	BURLING -TON	CAMDEN CC	CAPE MAY	CUMBER -LAND	ESSEX	GLOUCHES -TER	HUDSON
0	76770	2091	9410	3035	3758	612	1756	11593	1339	6953
1000	7689	174	1289	414	405	60	196	1542	118	617
1100	111	7	117	31	29	0	7	108	5	25
1110	1	0	7	0	2	0	0	7	0	2
1120	6	0	10	2	2	0	0	9	0	2

ANNUAL OPENINGS DUE TO REPLACEMENT DEMAND

	HUNTER -DON	MERCER	MIDDLE -SEX	MONMOUTH	MORRIS	OCEAN	PASSAIC	SALEM	SOMER -SET	SUSSEX
0	690	4292	5690	4068	4094	1554	5229	777	2426	634
1000	74	752	783	643	833	158	525	92	330	105
1100	3	36	41	65	109	7	52	5	41	4
1110	0	2	3	3	7	0	3	0	1	0
1120	0	3	3	4	9	0	4	0	2	0

ANNUAL OPENINGS DUE TO REPLACEMENT DEMAND

	UNION	WARREN
0	7765	911
1000	1209	110
1100	127	5
1110	8	0
1120	11	0

ANNUAL OPENINGS DUE TO REPLACEMENT DEMAND

	UNION	WARREN
0	146	24
1000	5	18
1100	316	31

REPORT NUMBER 6

TOTAL ANNUAL OPERATIONS

NEW JERSEY	ATLANTIC	MERGEN	BURLING -TON	CAMDEN CO	CAPE MAY	CUMBER -LAND	ESSEX	GLOUCES -TER	HUDSON
136887	3741	20132	5999	4868	1113	3102	13139	2486	7929
22921	382	3214	1674	788	141	476	2875	303	1524
2322	25	411	106	30	3	29	319	5	85
5	4	88	1	23	0	0	81	0	21
23	4	91	7	23	0	1	83	0	21

1817	63	285	64	20	30	64	16	38	-10
-256	22	-12	-7	-4	0	9	-15	-64	-2
3652	96	313	294	204	51	98	479	76	110

TOTAL ANNUAL OPERATIONS

HUNTER -DON	MERCER	MIDDLE -SEX	MONMOUTH	MORRIS	OCEAN	PASSAIC	SALEY	SOMER -SET	SUSSEX
1310	6871	12150	8613	10052	3727	8408	1165	5718	1217
200	1759	2249	1789	2624	436	1060	217	955	281
7	140	154	163	527	27	214	18	173	11
0	27	32	34	84	1	41	0	3	0
0	28	32	35	86	1	42	1	11	0

19	31	235	170	168	139	101	13	126	26
-44	-7	4	-88	-28	-43	-2	6	126	-51
78	258	249	470	240	101	39	60	109	46

TOTAL ANNUAL OPERATIONS

UNION	WARREN
12477	1581
3286	273
516	18
98	0
101	1

200	18
-11	-42
433	48

E. COMMENTS AND SYSTEM ERROR MESSAGES

The algorithm, as implemented in LIONS, requires an extensive amount of data. The preparation of such a quantity of data invariably is not error free. Detailed editing programs have therefore been incorporated within LIONS to detect data input errors.

The editing programs have been endowed with sufficient sophistication to distinguish different levels of severity in errors. Four such levels exist within LIONS.

- Level 0 errors are frequently not really errors at all. This warning message is simply printed to apprise the user of a possible error in the input. The system possesses logic to handle the anomolous condition. No action is required by the user other than to confirm that his input is as intended. The system will continue its execution.

- Level 1 errors are typically errors in data which will not affect computations. LIONS will inform the user of the error but will continue its execution.

- Level 2 errors are caused by inputs which would result in invalid results. Execution is continued until the completion of the subroutine in which the error occurred.

- Level 4 errors are so called "fatal" errors. Execution is terminated immediately.

All error messages indicate the subroutine in which the error was detected, the level of the error, and data related to the condition which, together with the material in this explanatory section, will be

sufficient to allow the user to identify and correct the error. The tables on the following pages are arranged according to algorithm and contain a list of possible error conditions for each algorithm. Following this material, several examples will be presented.

Sub-routine	Severity Level	Meaning	Data contents for								
			1	2	3	4	5	6	7	8	
RS	2	A code index is negative or larger than the allocated space	input code	input code index	input "across" code index	input "down" code index	allocated space	0	0	0	0
	2	More than one card for same index	input code	input code index	input "across" code index	input "down" code index	previous code	0	0	0	0
	2	A self loop has been defined: "down" or "across" equals input index	input code	input code index	input "across" code index	input "down" code index	0	0	0	0	0
WSB	4	More than 200 codes (implies loop in code structure)	current level	code	number of areas	count ("201")	0	0	0	0	0
RE	0	Employment already given for code for male or combined (new is added to old)	input code	input code index	input new employment	old employment	0	0	0	0	0
	0	Employment already given for code for female (new is added to old)	input code	input code index	input new employment	old employment	0	0	0	0	0
	0	Input code is not in structure	input code	input code index	input employment	"-1"	0	0	0	0	0
	2	Input code index does not match input code according to structure	input code	input code index	input employment	expected code	0	0	0	0	0
AGGRE	1	No structure is associated with the parent category (index 1)	parent index	"down" from parent	"across" from parent	code for parent	employment for parent	0	0	0	0
	0	Aggregated value for category not equal to input value (only reported if input was nonzero and aggregated value is used)	category index	"down" from category	"across" from category	code for category	input employment for category	aggregated employment for category	depth for category	0	0
ELIM	2	Category to be eliminated has as much or more employment as its predecessor (elimination algorithm not applicable)	number of elimination	predecessor category index	elimination category index	code of predecessor category	code of elimination category	employment in predecessor category	employment in elimination category	0	0

Algorithm A

Comment, Warning, and Error Messages

Sub-routine Number	Severity Level	Meaning	Data Contents for							
			1	2	3	4	5	6	7	8
2	2	No "down" category from predecessor	number of elimination	predecessor category index	elimination category index	code of predecessor category	code of elimination category	"0"	0	0
RS RE ELIM	4	Severity 2 errors occurred during execution of indicated subroutine	0	0	0	0	0	0	0	0
ERRMS	4	More than 100 severity 2 errors occurred during execution of a calling subroutine	0	0	0	0	0	0	0	0

Note:

Severity levels have the following meanings

- 0 - Comment - information - no action
- 1 - Warning - usually error in data which does not interfere with computations - no action
- 2 - Error - error which will cause invalid results - will continue until end of subroutine
- 3 - Fatal Error - error which prevents further computations - stops immediately

Sub-routine	Severity Level	Number	Meaning	Data Contents for								
				1	2	3	4	5	6	7	8	
RC	1	1	"I" is missing from column 2 in data set 1	"I"	input industrial identifier	input from-area code	input to-area code	input total commuting	input: total commuting area code	expected from-area code	expected to-area code	0
	2	2	From-area code is not as expected in data set 1	expected from-area code	input from-area code	input to-area code	input total commuting	expected to-area code	0	0	0	0
	2	3	To-area code is not as expected in data set 1	expected to-area code	input to-area code	input from-area code	input total commuting	expected from-area code	0	0	0	0
	1	4	Sum of fractions read from data set 1 does not sum to 100% within $\pm 1\%$ tolerance	sum of fractions	sum of fractions	input from-area code	input to-area code	input total commuting	input total commuting	expected from-area code	expected to-area code	0
RSNE	1	1	Record read from FILEB does not match expected area	input area number	expected area number	0	0	0	0	0	0	0
RFE	1	1	Record read from FILEB does not match expected area	input area number	expected area number	0	0	0	0	0	0	0
RCC	1	1	"CA" is missing from columns 1-2 in data set 2	"CA"	input identifier	input area code	area index (sequential)	0	0	0	0	0
	2	2	Area code is not as expected in data set 2	expected area code	input area code	area index (sequential)	0	0	0	0	0	0
	1	3	Industry employments do not total to input total employment in data set 2	sum of industry employment	input total employment	input area code	area index (sequential)	0	0	0	0	0
RS	2	1	A code index is negative or larger than the allocated space	input code	input code index	input "across" code index	input "down" code index	allocated space	0	0	0	0
	2	2	More than one card for same index	input code	input code index	input "across" code index	input "down" code index	previous code	0	0	0	0
	2	3	A self loop has been defined: "down" or "across" equals input index	input code	input code index	input "across" code index	input "down" code index	0	0	0	0	0



Algorithm B

Comment, Warning, and Error Messages

Sub-routine	Severity Level	Meaning	Data Contents for									
			1	2	3	4	5	6	7	8		
WSB	4	More than 200 codes (implies loop in code structure)	current level	code	number of areas	count ("201")	0	0	0	0	0	0
RC RS RCC	4	Severity 2 errors occur during execution of indicated subroutine	0	0	0	0	0	0	0	0	0	0
ERRMS	4	More than 100 severity 2 errors occurred during execution of a calling subroutine	0	0	0	0	0	0	0	0	0	0

Note:

Severity levels have the following meanings

- 0 - Comment - information - - no action
- 1 - Warning - usually error in data which does not interfere with computations - no action
- 2 - Error - error which will cause invalid results - will continue until end of subroutine
- 4 - Fatal error - error which prevents further computations - stops immediately

Sub-routine	Number	Severity Level	Meaning	Data Contents for									
				1	2	3	4	5	6	7	8		
REM	2	1	Input code is not in structure (county)	input code	input code index	0	0	0	0	0	0	0	0
	3	2	Input code index does not match input code according to structure (county)	input code	input code index	expected code	0	0	0	0	0	0	0
	4	1	Input code is not in structure (State, LMA)	input code	input code index	0	0	0	0	0	0	0	0
	5	2	Input code index does not match input code according to structure (State, LMA)	input code	input code index	expected code	0	0	0	0	0	0	0
AV	1	1	March, 1960 CES employment is zero while April is not for indicated area and industry	area index	industry index	March employment	April employment	0	0	0	0	0	0
	2	1	April, 1960 CES employment is zero while March is not for indicated area and industry	area index	industry index	March employment	April employment	0	0	0	0	0	0
RATIO	3	1	Ratio is zero for parent category and no substitute is available for indicated area	parent category index "1"	"down" for parent category	"across" for parent category	area index	0	0	0	0	0	0
	2	1	No structure is associated with the parent category for indicated area	parent category index	"down" for parent category	"across" for parent category	area index	0	0	0	0	0	0
NR	1	2	1960 ratio of total to wage & salary employment is zero for indicated industry (trend 1.0 by default)	input 1960 ratio	input 1975 ratio	input industry index	input industry code	0	0	0	0	0	0
	2	2	Input code is not in structure	input 1960 ratio	input 1975 ratio	input industry index	input industry code	expected code	0	0	0	0	0
RS	1	2	A code index is negative or larger than the allocated space	input code	input code index	input "across" code index	input "down" code index	allocated space	0	0	0	0	0

Comment, Warning, and Error Messages

Algorithm C

Sub-routine Number	Severity Level	Meaning	Data Contents for							
			1	2	3	4	5	6	7	8
2	2	More than one card for same index	input code	input code index	input "across" code index	input "down" code index	previous code	0	0	0
3	2	A self loop has been defined: "down" or "across" equals input index	input code	input code index	input "across" code index	input "down" code index	0	0	0	0
WSB 1	4	More than 200 codes (implies loop in code structure)	current level	code	number of areas	count ("201")	0	0	0	0
REM NR RS 99	4	Severity 2 errors occurred during execution of indicated subroutine	0	0	0	0	0	0	0	0
ERRMS 99	4	More than 100 severity 2 errors occurred during execution of a calling subroutine	0	0	0	0	0	0	0	0

Note:

Severity levels have the following meanings

- 0 - Comment - information
- 1 - Warning - usually error in data which does not interfere with computations
- 2 - Error - error which will cause invalid results
- 3 - Fatal Error - error which prevents further computations

no action

no action

will continue until end of subroutine

stops immediately

Sub-routine	Severity Level	Meaning	Data Contents for							
			1	2	3	4	5	6	7	8
RIOL	1	First card in data set 3 contains levels for which calculations are to be made. First three fields should be blank but are not, indicating probable omission of card	first input field	second input field	third input field	0 if level 1 to be done	0 if level 2 to be done	0 if level 3 to be done	0 if level 4 to be done	0 if level 5 to be done
	2	Card sequence number in data set 3 does not match expected value	input card sequence number	input industry code	input index	expected sequence number	0 if code is at level 1	0 if code is at level 2	0 if code is at level 3	0 if code is at level 4
	3	Input code index in data set 3 does not match input according to structure	input index	input industry code	expected code	sequence number	0	0	0	0
	4	Card sequence number in data set 4 does not match expected value	input card sequence number	input occupation code	input occupation index	0	0	0	0	0
	5	Input code index in data set 4 does not match input according to structure	input occupation code	expected code	input occupation index	0	0	0	0	0
ROC OPE	2	Index greater than allocated space in data set 2	input occupation code	(same as first field)	input index	allocated space	0	0	0	0
	2	Entry already made for indicated occupation	input occupation code	expected code	input code index	0	0	0	0	0
XPA ND	1	Input code is not in structure for covered industrial employment ratios	input code	input code index	"-1"	0	0	0	0	0
	2	Input code index does not match input according to structure	input code	input code index	expected code	0	0	0	0	0
CHECK	1	Fractions do not sum to 1.0 (1.0005) for covered industrial employment ratios	sum	ratio for first area	input code	input code index	first area of sum on card	last area of sum on card	0	0
AGGRE	1	No structure is associated with the parent category	parent index "1"	"down" from parent	"across" from parent	0	0	0	0	0

Sub-routine	Severity Number	Severity Level	Meaning	Data Content for							
				1	2	3	4	5	6	7	8
RNM	1	2	Industry code does not match that on the natural matrix tape	sequence number of industry	sequence number of occupation	industry index	occupation index	tape 1960 industry code	tape 1975 industry code	industry code	tape 1960 occupation code
	2	1	-Suppressed								
	3	2	Year read from tape does not match expected year	sequence number of industry	sequence number of occupation	industry index	occupation index	tape year (1950 expected)	tape year (1975 expected)	tape 1960 industry code	tape 1960 occupation code
WOCF	1	1	1960 employment is zero & 1975 is not, occupational change factor set to one	1960 employment	1975 employment	area index	occupation code	0	0	0	0
RS	1	2	A code index is negative or larger than the allocated space	input code	input code index	input "across" code index	input "down" code index	allocated space	0	0	0
	2	2	More than one card for same index	input code	input code index	input "across" code index	input "down" code index	previous code	0	0	0
	3	2	A self loop has been defined: "down" or "across" equals input index	input code	input code index	input "across" code index	input "down" code index	0	0	0	0
WSB	1	4	More than 200 codes (implies loop in code structure)	current level	code	number of areas	count ("201")	0	0	0	0
RIOL ROCODE XPAND RS	99	4	Severity 2 errors occurred during execution of indicated subroutine	0	0	0	0	0	0	0	0
ERRMS	99	4	More than 100 severity 2 errors occurred during execution of a calling subroutine	0	0	0	0	0	0	0	0

Sub-routine	Number	Severity Level	Meaning	Data Contents for							
				2	3	4	5	6	7	8	
RE	3	1	Input code is not in structure	input code	input employment	"-1"	0	0	0	0	0
	4	2	Input code index does not match input code according to structure	input code	input employment	expected code	0	0	0	0	0
AGGRE	1	1	No structure is associated with the parent category (index 1)	parent index "i"	"across" from parent	code for parent	employment for parent	0	0	0	0
	2	0	Aggregated value for category not equal to input value (only reported if input was nonzero and aggregated value is used)	category index	"down" from category	code for category	input employment for category	aggregated employment for category	depth for category	0	0
SUBT	1	1	In subtracting major county employment from state totals, a negative value resulted and was set to zero	occupation index	difference after subtraction	0	amount subtracted	0	0	0	0
RAP	1	4	No structure is associated with the parent category (index 1)	parent code index "i"	0	0	0	0	0	0	0
	2	1	There is employment to distribute but not residual employment to prorate to	occupation index	level	amount to be distributed	residual employment "0"	0	0	0	0
RS	1	2	A code index is negative or larger than the allocated space	input code	input code index	input "down" code index	input "across" code index	allocated space	0	0	0
	2	2	More than one card for same index	input code	input code index	input "down" code index	input "across" code index	previous code	0	0	0
	3	2	A self loop has been defined: "down" or "across" equals input index	input code	input code index	input "down" code index	input "across" code index	0	0	0	0
WSB	1	4	More than 200 codes (implies loop in code structure)	current level	code	count ("20")	number of areas	0	0	0	0

Comment, Warning, and Error Messages

Sub-routine	Number	Severity Level	Meaning	Data Contents for									
				1	2	3	4	5	6	7	8		
RS RE	99	4	Severity 2 errors occurred during execution of indicated sub-routine	0	0	0	0	0	0	0	0	0	0
ERRMS	99	4	More than 100 severity 2 errors occurred during execution of a calling sub-routine	0	0	0	0	0	0	0	0	0	0

Note:

Severity levels have the following meanings

- 0 - Comment - information - no action
- 1 - Warning - usually error in data which does not interfere with computations - no action
- 2 - Error - error which will cause invalid results - will continue until end of sub-routine
- 3 - Fatal Error - error which prevents further computations - stops immediately

Sub-routine	Severity Level	Meaning	Data Contents for								
			1	2	3	4	5	6	7	8	
RC	1	"1" is missing from column 2 in data set 1	"1"	input occupational identifier	input from-area code	input to-area code	input total commuting	input total commuting	expected from-area code	expected to-area code	0
	2	From-area code is not as expected in data set 1	expected from-area code	input from-area code	input to-area code	input total commuting	input total commuting	expected from-area code	0	0	0
	3	To-area code is not as expected in data set 1	expected to-area code	input to-area code	input from-area code	input total commuting	input total commuting	input total commuting	0	0	0
	4	Sum of fractions read from data set 1 does not sum to 100% within + 1% tolerance	sum of fractions	sum of fractions	input from-area code	input to-area code	input total commuting	input total commuting	input total commuting	expected from-area code	expected to-area code
RCC	1	"CA" is missing from columns 1-2 in data set 2	"CA"	input identifier	input area code	input area code	area index (sequential)	0	0	0	0
	2	Area code is not as expected in data set 2	expected area code	input area code	area index (sequential)	0	0	0	0	0	0
	3	Occupational employments do not total to input employment in data set 2	sum of occupational employment	input total employment	input area code	input area code	area index (sequential)	0	0	0	0
RS	1	A code index is negative or larger than the allocated space	input code	input code index	input "across" code index	input "down" code index	allocated space	0	0	0	0
	2	More than one card for same index	input code	input code index	input "across" code index	input "down" code index	previous code	0	0	0	0
WSB	3	A self loop has been defined; "down" or "across" equals input index	input code	input code index	input "across" code index	input "down" code index	0	0	0	0	0
	4	More than 200 codes (implies loop in code structure)	current level	code	number of area	count ("201")	0	0	0	0	0

Comments, Warning, and Error Messages

Sub-routine Number	Severity Level	Meaning	Data Contents for									
			1	2	3	4	5	6	7	8		
RC RS RCC	4	Severity 2 errors occur during execution of indicated subroutine	0	0	0	0	0	0	0	0	0	0
ERRMS	4	More than 100 severity 2 errors occurred during execution of a calling subroutine	0	0	0	0	0	0	0	0	0	0

Note:

Severity levels have the following meanings

- 0 - Comment - information - no action
- 1 - Warning - usually error in data which does not interfere with computations - no action
- 2 - Error - error which will cause invalid results - will continue until end of subroutine
- 4 - Fatal error - error which prevents further computations - stops immediately

Sub-routine	Severity Level	Meaning	Data Contents for										
			1	2	3	4	5	6	7	8			
RDR	2	Input code index in death & retirement rate data does not match input code according to structure (or is not in the structure)	death & retirement rate	(same as first field)	input code	input code index	0	0	0	0	0	0	0
AGGRE	1	No structure is associated with the parent category (index 1)	parent index "1"	"down" from parent "0"	"across" from parent	code for parent	employment for parent	0	0	0	0	0	0
RS	2	A code index is negative or larger than the allocated space	input code	input code index	input "across" code index	input "down" code index	allocated space	0	0	0	0	0	0
	2	More than one card for same index	input code	input code index	input "across" code index	input "down" code index	previous code	0	0	0	0	0	0
	2	A self loop has been defined: "down" or "across" equals input index	input code	input code index	input "across" code index	input "down" code index	0	0	0	0	0	0	0
WSB	4	More than 200 codes (implies loop in code)	current level	code	number of areas	count ("201")	0	0	0	0	0	0	0
RDR	4	Severity 2 errors occurred during execution of indicated subroutine	0	0	0	0	0	0	0	0	0	0	0
ERRMS	4	More than 100 severity 2 errors occurred during execution of a calling subroutine	0	0	0	0	0	0	0	0	0	0	0

Note:

Severity levels have the following meanings

- 0 - Comment - Information - no action
- 1 - Warning - usually error in data which does not interfere with computations - no action
- 2 - Error - error which will cause invalid results - will continue until end of subroutine
- 3 - Fatal Error - error which prevents further computations - stops immediately

Three sets of warning messages are shown in Figures E-1 through E-3 to illustrate the format of the messages and their interpretation. The preceding tables are used in this process.

Figure E-1 shows a comment which occurred in the processing of data set 5. This condition arose during execution of Algorithm A. Referring to the chart for A, we find that the second condition in AGGRE is that an aggregated value for the category was not equal to an input value. The index is number 1 (the parent node with code 000000). It also notes that the next code below number 1 is number 161 and that none are on the same level (level 1). The input employment is 38732, while the aggregated value is 38731 indicating some input value is off by one person.

Figure E-2 shows a series of comments which arose during execution of Algorithm B. Referring to the chart for B, we find that the fourth condition in RC is that the sum of fractions read from the data set 1 does not sum to 100% with $\pm 1\%$ tolerance. Of particular interest are data items 1 (the sum as a fraction) and data items 3 and 4 (the from- and to- area codes). Some are quite close (e.g. from 3, to 12, is off by 1.6%) and others are quite far off (e.g. from 2, to 19, is low by 14.5%). In all these cases, the fractions are normalized to assure proper summation.

Figure E-3 shows a series of comments which arose during execution of Algorithm D. Referring to the chart for D, we find that the first condition in CHECK is that the fractions do not sum to 1.0 (within $\pm .0005$) for covered industrial employment ratios. Of parti-

cular interest are data items 1 (the sum), data items 3 (the industry code), and data items 5 and 6 (the first and last areas involved in the summation). The first line indicates a case in which no fractions were provided so that the sum was zero. Others indicate slight and substantial differences from 1.0.

```

PROCESSING DATA SET 5
COMMENT OR WARNING NUMBER 2 IN SUBROUTINE AGGRE
DATA.. 1 161 0 0 38732 38731 1 0

```



COMMENT OR WARNING NUMBER	4	IN SUBROUTINE RC					
DATA..							
0.855000	0.855000	2	19	90	2	19	0
COMMENT OR WARNING NUMBER	4	IN SUBROUTINE RC					
DATA..							
1.015999	1.015999	3	12	40	3	12	0
COMMENT OR WARNING NUMBER	4	IN SUBROUTINE RC					
DATA..							
1.180996	1.180996	4	25	154	4	25	0
COMMENT OR WARNING NUMBER	10	IN SUBROUTINE RC					
DATA..							
1.039000	1.039000	10	26	432	10	26	0
COMMENT OR WARNING NUMBER	4	IN SUBROUTINE RC					
DATA..							
0.965000	0.965000	11	13	360	11	13	0
COMMENT OR WARNING NUMBER	4	IN SUBROUTINE RC					
DATA..							
0.965000	0.965000	11	15	199	11	15	0
COMMENT OR WARNING NUMBER	4	IN SUBROUTINE RC					
DATA..							
0.965000	0.965000	11	26	703	11	26	0

FIGURE E-2

COMMENT OR WARNING NUMBER	1	IN SUBROUTINE CHECK							
DATA..									
0.0	0.0	101300	10	9	10	0	0	0	0
COMMENT OR WARNING NUMBER	1	IN SUBROUTINE CHECK							
DATA..									
0.999300	0.409000	310000	14	4	6	0	0	0	0
COMMENT OR WARNING NUMBER	1	IN SUBROUTINE CHECK							
DATA..									
1.278799	0.139200	523000	70	1	3	0	0	0	0
COMMENT OR WARNING NUMBER	1	IN SUBROUTINE CHECK							
DATA..									
1.001100	0.747400	413000	79	7	8	0	0	0	0
COMMENT OR WARNING NUMBER	1	IN SUBROUTINE CHECK							
DATA..									
1.001100	0.747400	414000	80	7	8	0	0	0	0

FIGURE E-3

APPENDIX F1

DETAILED STATEMENT OF THE ALGORITHM

(This methodology was developed and documented by Gary King, Division of Planning and Research, New Jersey Department of Labor and Industry.)

APPENDIX F1

Detailed Statement of the Algorithm

A) Inputting and Editing April 1st 1960 Census Industrial Employment

- 1) Input Special Industry Code Structures, Levels II S through VIII S: Items: XV B); 1-7.
- 2) Input April 1st 1960 Census Industrial Male Employment, Statewide (Code: 00); Item: I A); 1.
- 3) Add all employment figures having the same industrial codes from 2) above; to create an unambiguous storage of employment by industry code.
- 4) Aggregate all data obtained in 3) above having level VIII S industry structure codes into the corresponding level VII S structures codes.
- 5) List the discrepancies between the aggregations obtained in 4) above with the data obtained in 3) above which have Level VII S industry structure codes.
- 6) Using the aggregations obtained rather than the adjusted input data obtained in step 3) above, repeat steps 4) and 5) above for industry code structures VI S through IV S respectively, substituting in sequence VII S for VIII S, VI S for VII S; then, V for VI S, etc. Also repeat steps 4) and 5) finally for Industry code 000000, "Total Industrial Employment and IV S respectively.

- 7) Subtract employment figure code 009999 from employment figure coded 000000. Using aggregations obtained rather than inputted data with these codes.
- 8) Divide the result obtained in 7) above into the employment figure coded 000000, and retain answer to five decimals.
- 9) Multiply ratio obtained in step 8) above times the employment figures of each code in industry code level structures IV S through VIII obtained in steps 4) and 6) above. Round results to the units place.
- 10) Repeat steps 7) and 8) above for the following industry code pairs: a) 309999 and 320000, b) 510999 and 510000, c) 322009 and 322000, and d) 424909 and 424900 respectively. The first code of the above pairs should correspond to 009999 and the second supplant code 000000.
- 11) Multiply ratio obtained from pair a) in step 10) above times empty in all codes whose first two digits are 32_ _ _ _ excepting industry code 320000. Round results to units place.
- 12) Multiply ratio obtained from pair b) in step 10) above times empty in all codes whose first two digits are 51_ _ _ _ excepting 510000. Round results to units place.
- 13) Multiply ratio obtained from pair c) in step 10) above times empty in all codes whose first digits are 3220_ _ excluding code 322000. Round results to the units place.

- 14) Multiply ratio obtained from pair d) in step 10) above times empty in all codes whose first four digits are 4249-- excepting code 424900. Round results to units place.
- 15) Note: step 10) above should include additional pair, e) 520999 and 520000, and step 15) should be: Multiply ratio obtained from pair e) in step 10) above times employment in all codes whose first two digits are 52----- . Round results to units place.
- 16) Create unambiguous storage record of employment figures for each industry code contained in levels IV S through VIII S by using the results of steps 3), 4), 6) and 11) through 14) above. Also include code 000000.
- 17) Eliminate information from the record obtained in step 15) above which have codes: 009999, 309999, 322009, 424909, 520999, and 510999.
- 18) Using codes of industry code structure level IV S aggregate data to a level IV S industry code structure. Add new information with unique codes to data record obtained in step 16) above.
- 19) Repeat steps 2) through 18) above for all other April 1st 1960 Census Male Industrial Employment by area. Input items: I: A); 2) and 3). Then, Major County Areas. Items: I: B); 1) through 11).

- 20) Repeat steps 2) through 18) above for all April 1st 1960 Census Industrial Female Employment by area. Items: II: A); 1) through 3). Then, items: II: B); 1) through 11).
- 21) By geographic area by industrial code add together the records obtained of April 1st 1960 Census Male Industrial Employment to the records obtained of April 1st 1960 Census Female Employment Industrial to create one storage record entitled, "April 1st 1960 Census Total Both Sexes Industrial Employment."
- 22) Input April 1st 1960 Census Industrial Employment, Total Both Sexes for Burlington County. Item: III: A); 1), (Code: 03).
- 23) Aggregate all data inputted in step 22) above which have Level V S codes into a corresponding Level IV S industry code structure.
- 24) Compare the Level IV S industry code structure aggregations obtained in step 23) above with the inputted data of step 22) above having the Level IV S industry codes. List discrepancies.
- 25) Aggregate the Level IV S industry code aggregations obtained in step 23) above into a Total Employment classification, code 000000.
- 26) Using the data obtained in the steps above, repeat steps 7) and 8) above.

- 27) Multiply the ratio obtained times all employment figures obtained in steps 22) and 23) above having level V S and IV S industry structure codes.
- 28) From the results of steps 22), 23), 24), and 27) above create an unambiguous storage record of employment for each industry code contained in industry code structure levels IV S and V S. Also code 000000.
- 29) Repeat step 18) above, but add new information with unique codes to data record obtained in step 28) above.
- 30) Eliminate employment coded 009999 from storage record.
- 31) Repeat steps 22) through 30) above for all other April 1st 1960 Census Industrial Employment, Total Both Sexes, Minor County Areas. Items: III: A); 2) Cape May (Code: 05) through 10) Warren (Code: 21).
- 32) Combine the storage record created in step 21) above with the record created in steps 28) through 31) above to create one record of April 1st 1960 Census, Total Both Sexes - Industrial Employment by area by industry.
- 33) On both a level IV S and a level V S industry code structure add the employment of areas 03, 04, 08 and then similarly add areas 12 and 18 to obtain a storage record of industry employment on both level IV S and V S industry code structure level on a level III G geographical code structure level.

- 34) Repeat step 33) above for an industry code structure level II S.
 - 35) Combine the results of steps 32) through 34) to create a final storage record. Eliminating industry data storage records of areas 03, 04, 08, 12, and 18.
- B) Converting April 1, 1960 Census Industrial Employment, Total Both Sexes from a Residence based employment concept to an establishment based concept.
- 1) ^{**} Input item [X A: 01], April 1st 1960 Census Industrial Employment Commutation in Atlantic County (Code:01).
 - 2) For each geographical area, (Code: 02-25) add percentage of each industry code. Compare aggregation to 100 percent and list discrepancies of more than 1 percent (data check)
 - 3) For each geographical area aggregate the percentages coded 710000, 720000, 730000, and 740000 to a total for industry coded 700000.
 - 4) Convert all percentages to employment figures by multiplying the percentages for each industry times the corresponding employment figure for each given area.
 - 5) For each industry code (corresponding to industry code structure Levels II S and III S) sum results across all areas (Codes: 02-26).
 - 6) Retain all summations. (This represents the employment commuting out of Atlantic County by industry.)

- 7) Retain the results obtained in step 4) above for each industry for each area. (Each figure represents the employment from Atlantic County by industry commuting into another area.)
- 8) Repeat steps 1) through 7) above for all other input items [V A: 2) through 25].
- 9) By industry code by area add the results obtained in step 8) above. (This aggregation will give the total in commutation of employment by industry of a geographic area from all other areas.)
- 10) By industry code by area code subtract the results obtained in step 6) above from the results obtained in step 9) above.
- 11) Retain the results from step 10) above. (This information gives the net commutation of industry employment by area.)
- 12) By industry code add together the results of step 11) above of the various appropriate geographic areas to create a data record having a Level III G geographical code structure.
- 13) For each employment figure having a Level III S industry code, and by area add the results of step 12) above to the results of step A): 35) above.
- 14) For each employment figure having a level II S industry code, and by area add the results of step 12) above to the results of steps A): 35) above.
- 15) Create an unambiguous storage record of the results of

steps 13) and 14) above. The record will give the establishment employment of a geographic areas: 09, 11, 05, 06, 10, 15, 17, 19, 21, 29, 30, 28, and 31; either on a level II S industry code structure or a level III S code structure.

- 16) Input April 1st 1960 Census Employment Commutation Control Figures: Item XI: A): 1) and 2).
- 17) Aggregate by area the commutation control figures from a industry code structure level of III S to a II S level.
- 18) Multiply the commutation control figures of area 33 by the factor 1.3032.
- 19) Using the "two dimensional iterative proration technique" prorate the results of step 15) above to adjusted commutation control figures obtained in steps 16) through 17) above. The commutation control figures are on a level II G geographical code structure and the results of 15) above are on a level III G geographical code structure level. For area coded 33 of the commutation control figures a level II S industry code structure should be used. For all other areas which have control figures, (e. g., 09, 11, 29, and 30) a level III S industry code structure is appropriate. Last iteration on proration of matrix should be on the industry employment figures.

- 20) By area by industry storage record should be created of the adjusted figures obtained in step 19) above. Record is on a level III G geographical code structure and either a level II S or level III S industrial code structure depending on the area.
- 21) By area by industry divide the results of step 20) above by the data obtained in step A): 35) which has the corresponding area and industry code. Results should be to five decimals.
- 22) Multiply by area the ratio coded 001111 by all industry employment coded with a 1st digit of either 0_..... or 1_..... of that given geographic area. This should be done for each area in a level III G geographical code structure. Industry code 000000 should be excluded from adjustment. (Data source: step A): 35) above.)
- 23) Repeat step 22) above for industry code 200000 and all industry codes whose 1st digit is 2_.....
- 24) Repeat step 22) above for industry code 300000 and all industry codes whose 1st digit is 3_.....
- 25) Repeat step 22) above for industry code 400000 and all industry codes whose 1st digit is 4_.....
- 26) Repeat step 22) above for industry code 500000 and all industry codes whose 1st digit is 5_.....

- 27) Repeat step 22) above for industry code 600000 and all industry codes whose 1st digit is 6_.....
- 28) Repeat step 22) above for industry code 700000 and all industry codes whose 1st digit is 7_.....
- 29) Repeat step 22) above for industry code 710000 and all industry codes whose 1st four digits are either 7073, 7075, or 7076.
- 30) Repeat step 22) above for industry code 720000 and all industry codes whose 1st four digits are either 7070, 7072, or 7088.
- 31) Repeat step 22) above for industry code 730000 and all industry codes whose 1st four digits are either 7078, or 7079
- 32) Repeat step 22) above for industry code 740000 and all industry codes whose 1st four digits are either 7080, 7081, 7086, or 7089.
- * 33) Repeat step 22) above for industry code 000000 and industry code 000000.
- 34) Using the results of steps 22) through 33) above create storage record involving all codes in levels II through V major standard industrial code structures, for areas 09, 11, 29, 13, 01, 30. Also soce: 000000.
- 35) Using the results of steps 22) through 33) above create storage record including all code in level II major standard industrial code structure for areas 28, 31, 05, 06, 10, 15, 17, 19, and 21. Also, codes: 000000, 310000, and 320000.

* see step 37) below.

** see step 38) below.

- 36) Combine the results obtained in steps 34) and 35) above to create one storage record of April 1st 1960 Census, Total Both Sexes, Industrial Employment by geographic area (Level III G) on an establishment basis.
 - 37) Input the Major Standard Industry Code Structures; Items: XV: A); 1) through 5) - Between steps 33) and 34) above.
 - 38) Input the Standard Geographical Code Structures. Items: XV: C); 1) through 4) - Between steps 1) and 2) above.
- C) Calculation of 1960 and 1975 Industrial Employment: Annual Average, Total Employment, and Establishment Employment Basis.
- 1) Input March 1960 CES Industry Employment, State and Aggregated Labor Market Areas (Item: VI: A); 1) through 5)).
 - 2) Input March 1960 CES Industry Employment, Major County Areas. (Item: VI: B); 1) through 4)).
 - 3) Input March 1960 CES Industry Employment, Minor County Areas. (Item: VI: C); 1) through 7)).
 - 4) Using the "two dimensional iterative proration technique prorate employment data obtained in steps 1) through 3) above over an area by industry matrix. The area detail is on a level III G geographical code structure and the industry detail is a level II A industrial code structure. The horizontal limit of the matrix is state (Code: 00) employment on a level II industrial code structure and the vertical limit by the total

employment (Code: 000000) on a level III G geographical code structure.

- a) Add state (Code: 00) industrial employment on a level II, 100000, industrial code structure basis to a total employment figure (Code: 000000).
- b) Divide aggregation into given total employment figure for the state (Code: 00) industry code: 000000. Resulting ratio should be to five decimal places.
- c) Multiply ratio obtained times state (Code: 00) industrial employment on a level II industrial code structure basis.
- d) Retain results of c) above rounded to the units place.
- e) Add total employment (Code: 000000) on a level III G geographical code structure basis to a total employment figure (Code: 000000) for the state (Code: 00).
- f) Divide aggregation obtained in step 3) above into the given total industrial employment figure for the state (Code: 00) code: 000000. Resulting ratio should be to five decimal places.
- g) Multiply ratio times the total industrial employment (Code: 000000) of each area on a level III G geographical code structure.
- h) Retain results of g) above rounded to the units place.

- i) Continue steps e) through h) above for all industry codes in a level II industrial code structure. Using the results of step d) above as the given employment figure (dividend) for a given industry code.
 - j) Continue steps a) through d) above for all geographic codes in a level III G geographical code structure, using the results of step i) above as the data which is aggregated and the results of h) above as the given employment figure (Code: 000000) or dividend indicated in step b) above.
 - k) Repeat steps i) and j) above for at least three more iterations. The results of the preceding operation always become the input to be aggregated in the next operation, with the first results obtained in d) and h) above remaining fixed figures and always being the given respective dividends. Final iteration should always be with step j) above.
- 5) Retain storage record of the final results of step k) above. The nature of the data will be the employment for each industry code in a level II industrial level code structure for each geographic area code in the level III G geographical code structure, plus employment in code: 000000. In addition, there is also the state (Code: 00) employment figures for each code in a level II industrial code structure plus the total employment code: 000000.

- 6) Repeat steps 4) and 5) above; supplanting industry code: 000000 with code: 300000, and the level II industrial code structure with merely codes: 310000 and 320000. The employment figures for all 300000 codes should be obtained from the record created in step 5) above.
- 7) Repeat step 6) above; supplanting industry code: 300000 with industry code: 310000, and industry codes: 310000 and 320000 with all industry codes whose first two digits are 31_____ and last two are 00. Therefore; codes: 31XX00.
- 8) Repeat step 6) above; supplanting industry code: 300000 with industry code: 320000, and industry codes 310000 and 320000 with all industry codes whose first two digits are 32 and last two are 00. (e. g., codes: 32XX00).
- 9) Combine into one storage record the results obtained in steps 5) through 8) above.
- 10) For the geographic area, the state (Code: 00) using data available from step 1) above aggregate all employment whose codes have the first three digits 010XXX, divide the aggregation obtained into the employment figure coded : 010000 obtained in step 9) above. Ratio taken to five decimals.
- 11) Multiply the ratio times the employment figures which were used to obtain the aggregation. Round results to the units place.

12) Repeat steps 10) and 11) above for the following code configuration pairs:

- a) 101XXX and 100000
- b) 4XXX00 and 400000
- c) 5X0000 and 500000
- d) 606XXX and 600000
- e) 70XX00 and 700000
- f) 90XX00 and 900000

13) Using the results of step 12) above in combination with the data obtained from step 1) above instead of step 9) above, repeat steps 10) and 11) above for the following code configuration pairs.

- a) 41XX00 and 410000
- b) 42XX00 and 420000
- c) 52XX00 and 520000

14) Combine into one storage record the results obtained in steps 10) through 13) above and the results available from step 9) above which are employment figures for the state (Code: 00). This record then represents adjusted (to assure aggregation) employment figures for the state (Code: 00) for all industry codes in industry code structure levels II through IV inclusive.

- 15) Using the same techniques outlined in steps 10) through 13) above and the information available from steps 14) and 1) above respectively, prorate the employment figures for the state (Code: 00) obtained from step 1) above on a level V industry code structure to the corresponding level IV industrial code structure aggregations obtained in step 14) above.
- 16) Combine into one storage record the results of steps 14) and 15) above. This will give now the adjusted (to assure aggregation) employment figures for the state (Code: 00) for all industry codes in industry code structure levels II through V inclusive.
- 17) Repeat steps 10) through 16) for all geographical areas in the level III G geographical code structure except areas coded: 05, 06, 10, 15, 17, 19, and 21). In some instances, of course, depending on the geographic area, the source of information or data instead of being "step 1) above" will be either step 2) or step 3) above.
- 18) Combine the results of steps 16) and 17) above to create one storage record, March 1960 adjusted CES Industrial Employment. "Adjusted" here means adjusted to eliminate aggregational discrepancies.
- 19) Repeat steps 1) through 18) above for April 1960 CES Industrial Employment; Input item: VII: A) through C).

- 20) For the state (Code: 00) area add the results of step 18) above, "March 1960 adjusted CES Industrial Employment" to the eventual results of step 19) above "April 1960 adjusted CES Industrial Employment", for the state area (Code: 00). This should be done for all industry codes in industrial code structure levels II through V inclusive. Also: code: 000000.
- 21) Divide the results obtained for each industry code in step 20) above by two, to create a storage record identified as "Estimated April 1st 1960 CES Industrial Employment".
Note: if for some reason an industry code either has only a "March 1960 adjusted CES Industrial Employment" figure or an "April 1960 adjusted CES Industrial Employment" figure of greater than zero and the other month either April or March doesn't have an employment figure greater than zero, list the discrepancy. For the purpose of calculation assume the figure for the two months to be equal but equal to the figure greater than zero. This note: refers specifically to step 20) above not to step 21).
- 22) Repeat steps 20) and 21) averaging above for the following geographic areas: Codes: 09, 11, 29, 30, 28, 31, 13, 01.
- 23) Repeat steps 20) and 21) above for the following geographic areas: Codes: 05, 06, 10, 15, 17, 19, and 21. However, calculations should only be performed for all industry codes

in industry code structure levels II through III A inclusive, and total industrial employment, code: 000000.

- 24) Combine the results of steps 21) through 23) above to create one storage record of "Estimated April 1st 1960 CES Industrial Employment" by all industry codes in either industry code structure levels II through III A inclusive, or V inclusive and code: 000000 for all geographic areas in a level III G geographical code structure.
- 25) Repeat steps 1) through 18) above for 1960 Annual Average CES Industrial Employment; Input item: VIII A) through C).
- 26) By corresponding geographical code by corresponding industrial code, divide the available employment industrial, "April 1st 1960 CES....." figures from step 24) above into the eventual results obtained from step 25) above, "1960 Annual Average CES adjusted Industrial Employment". This will create a storage record of 1960 industrial employment calendar change ratios, by geographic area by industry. Again the geographic areas correspond to those included in a level III G code structure and the industries those included either in levels II through III A inclusive or V inclusive depending on the geographic areas. Also: code: 000000.
- 27) By corresponding geographic area by corresponding industry code for each industry code where there is an employment figure obtained in the results of step B): 36) above multiply

the employment figure by the industrial employment calendar change ratio for 1960 obtained in step 26) above.

- 28) Divide the results of step 27) above, by the industrial employment figure, in the storage record eventually obtained from step 25) above, with the corresponding geographic and corresponding industrial code; for each industry code where there is an employment figure available from the results of step 27) above, which is greater than zero. The resulting ratio should be taken to five decimal places.
- 29) Create an unambiguous storage record of the results of step 28) above. Each industry code which is unique in industry code structure levels II through III A inclusive, for each geographic area in a level III G geographical code structure should have a ratio greater than zero. If for a given industry code the ratio is at first zero supplant this with the ratio of the next most aggregated corresponding industry code which has a ratio value of greater than zero for the given geographical area.
- 30) Repeat step 29) above for each industry code which is unique in industry code structure levels IV and V inclusive for the following geographic areas; codes: 01, 09, 11, 13, 29, 30, 28, and 31.
- 31) Combine the results obtained in steps 29) and 30) above into one unambiguous storage record data is the "1960 New Jersey

Ratios of Wage and Salary to Total Employment by Industry."

- 32) By corresponding geographic code by corresponding industrial code multiply the data available in step 31) above times the industrial employment figures available from the storage record eventually obtained from step 25) above.
- 33) Repeat steps 4) through 18) - proration above for the industrial employment figures obtained in step 32) above. The resulting data storage record will be "1960 Total Industrial Employment." It is annual average, total employment, establishment employment figures by area.
- 34) Repeat steps 4) through 18) above for "Projected 1975 Annual Average CES Industry Employment," (input item: IX: A) through C).
- 35) Input National Ratios of Wage and Salary Employment To Total Employment by Industry; (item: XII: A) and B)).
- 36) By industry code divide the 1960 ratios available from step 35) above into the 1975 ratios available from step 35) above. Retain resulting ratios to 5 decimals. The results are identified as "National Ratios of Industrial Wage and Salary Employment to Total Employment 1960 to 1975 Trend Factors".
- 37) By geographic code, multiply the results obtained in step 31) above times the results obtained in step 36) above by corresponding industrial code.

- 38) Retain the results of step 37) above as an unambiguous storage record. It will have the same code classification characteristics as the data identified by step 31) above. It is identified as the "Projected 1975 New Jersey Ratios of Wage and Salary Employment by Industry."
- 39) By corresponding geographic code by corresponding industry code, multiply the results obtained in step 38) above times the 1975 adjusted Industrial Employment figures in storage record eventually obtained in step 34) above.
- 40) Repeat steps 4) through 18) above using the results obtained in step 39) above. The storage record eventually obtained is entitled, "Projected 1975 Total Industrial Employment." It is on an annual average, total employment, establishment employment by area concept.

D) Calculation of "New Jersey 1960 to 1975 Occupational Change Factors by Area"

- 1) Input "Covered Industrial Employment Ratios - 1960", [Item: XIII: A); 1) through 2)].
- 2) Input "Covered Industrial Employment Ratios - 1975", [Item: XIII: B); 1) and 2)].
- 3) Convert storage record obtained in step C), 40) above, "Projected 1975 Total Industrial Employment", from a level III G to a level IV G geographical code structure, by multiplying ratios available from step 2) above times the data available from step C); 41) above by their corresponding industrial structure level IV codes employment figures by appropriate geographic area code configurations.
- 4) For each geographic area unique to a level IV G geographical code structure aggregate the results obtained in step 3) above into level III A, III, II industrial code structures. Also, aggregate into a total employment code: 00.
- 5) Combine the results obtained in step C); 40, and steps 3) and 4) above into one unambiguous storage record. Record will include industry employment figures for all codes unique in either a level III G or IV G geographical code structure, and either industry code structure levels II through III A, or IV, or V inclusive, depending on the geographic area. Also code: 000000.

- 6) Repeat steps 3) through 5) above for "1960 Total Industrial Employment" obtained from step C); 3) above. Where appropriate data from step 1) above. Where appropriate data from step 1) above should be used in place of data from step 2) above.
- 7) Input "National B. L. S. Industrial Occupational Matrix Tape"; [Item: XVI].
- 8) For the following geographic code: 00 multiply the occupational percentages for 1960 on the National B. L. S. Industrial Occupational Matrix coded as industry 010000 times the New Jersey industry employment figure in the given geographic area coded 010000.
- 9) Repeat step 8) above for all other industry codes in a level II industrial code structure.
- 10) Sort the results of steps 8) and 9) above by occupation and aggregate by occupation.
- 11) Repeat steps 8) through 10) for 1975 data.
- 12) Input "Special Code Additions", [Item: XV, F)].
- 13) Perform "Special Code Additions" indicated in step 12) above on the employment data obtained in step 10) and 11) above, and eliminate from data all employment figures coded with the codes that are added to another code. Retain storage record.

- 14) By occupational code divide the 1960 employment figures obtained in step 13) above into the 1975 employment figures obtained by occupation.
- 15) Retain storage record of the 1960 to 1975 occupational change factors obtained in step 14) above.
- 16) Repeat steps 8) through 15) above for each geographic area either contained in a level III G or IV G.
- 17) Repeat steps 8) through 16) for industry code structure levels III and III A respectively.
- 18) For geographical codes: 00, 01, 13, 09, 11, 29, 30, 28, 31, 07, 14, 20, 02, 16, 03, 04; 08, 12 and 18 respectively for industry code structure level IV repeat steps 8) through 16).
- 19) For geographical codes: 01, 13, 09, 11, 28, 29, 30, 31, and 00; respectively for industry code structure level V, repeat steps 8) through 16).
- 20) By combining the results of steps 15) through 19) according to the geographical area and the industrial code structure level used in calculate, retain storage record of each 1960 to 1975 occupational change factor calculated.

E) Inputting and Editing April 1st 1960 Census Occupational Employment.

- 1) Inpute "Major Standard Occupational Code Structures"; [Item: XV; 1)].
- 2) Input "Special Occupational Code Structures"; [Item: XV: E)].
- 3) Input "April 1st 1960 Census Occupational Male Employment"; for the state (Code: 00); [Item: IV: A); 1)].
- 4) Add all employment figures having the same occupational codes to create an unambiguous storage record of data obtained in step 3) above by occupational code.
- 5) Aggregate all data obtained in step 4) above having occupational codes contained in a level IV O occupational code structure into a level III O occupational code structure.
- 6) Repeats steps A) 5) through 9) for occupational code structure level II O, and then occupational codes 0999 and 0000 respectively.
- 7) Create storage record of data obtained in steps 5) and 6) above, but eliminate data coded 0999 from record.
- 8) Aggregate data available from step 7) above into a level II OS occupational code structure and add to record all codes uniquely contained only in the level II OS occupational code structure.
- 9) Repeat steps 3) through 8) above for remainder of input, "April 1st 1960 Census Occupational Male Employment"; [Items: IV: A);

- 2) and 3)] and [IV: B); 1) through 11)].
- 10) Repeat steps 3) through 8) above for input entitled "April 1st 1960 Census Occupational Female Employment ", [Items: V: A); 1) through 3) and V: B); 1) through 11)].
 - 11) Input [Item: IV: C); 1) through 9)], "April 1st 1960 Census Occupational Male Employment", for Minor County Areas.
 - 12) Aggregate all codes of a level V OS occupational code structure into a level II OS code structure and eliminate code 0949 in the same manner as in the steps above.
 - 13) Repeat steps 11) and 12) for input [Item: V: C), 1) through 9)], "April 1st 1960 Census Occupational Female Employment", for Minor County Areas and for a level IV OS occupational code structure rather than a level V OS.
 - 14) Calculate missing occupational male employment figures for the minor county areas using the residual area percentage distribution technique.
 - 15) Repeat 14) above for female occupational employment figures.
 - 16) By geographical area by corresponding occupational code in all occupational code structure levels II O through IV O inclusive; add male and female employment. Also, do so for codes unique to code structure level II OS.

F) Converting April 1st 1960 Census Occupational Employment to an Annual Average, Total Employment Establishment basis.

- 1) Following the steps outlined in steps B) 1) through 36) convert the occupational employment figure to reflect net commutation between areas.
- 2) Prorate the results obtained in step 1) above to the total industrial employment of each area obtained in step C), 33) to convert employment in every occupational code for each area to an annual average basis.
- 3) Retain storage record of results of step 2) above. It is identified as "Total 1960 Occupational Employment", on an Annual Average, Total Employment, Establishment Employment basis.

G) Obtain 1975 Occupational Projections

- 1) For each occupational 1960 to 1975 change factor available in step 1), 2) by corresponding geographical area code by corresponding occupational code, multiply the results available from step F), 3) above times each give change factor.
- 2) Input "Estimated New Jersey 1960 Occupational Death and Retirement Rates", [Item: XIV].
- 3) Using the most detailed industrial code structure level based projections of 1975 occupational employment available for a given geographic area in step 1) above, and the "two dimensional iterative proration technique" outlined in steps C), 4) through 18) above adjust these 1975 projections to obtain one set of projections which aggregate in all directions.
- 4) By geographic area by level IV O occupational code interpolate linearly between "Total 1960 Occupational Employment", obtained in step F) 3) above and the results of step 3) above to the year 1973.
- 5) Multiply the results of 4) above times the ratios inputted in step 2) above by occupational code by area.
- 6) Aggregate the results of 5) above into a level III O occupational code structure. Also, aggregate to level II O and total occupational code: 0000. The result of 5) and 6) gives the number of annual average openings due to replacement demand, between 1971 and 1975.

APPENDIX F2

SUMMARY OF INPUT DATA
REQUIREMENTS

APPENDIX F2

Summary of Input Data Requirements

I April 1st 1960 Census Industrial Male Employment

A) State and Aggregated Labor Market Areas

- 1) State (Code: 00)
- 2) Newark L. M. A. (Code: 29)
- 3) Paterson - Clifton - Passaic L. M. A. (Code: 30)

B) Major County Areas

- 1) Atlantic (Code: 01)
- 2) Bergen (Code: 02)
- 3) Camden (Code: 04)
- 4) Essex (Code: 07)
- 5) Hudson (Code: 09)
- 6) Mercer (Code: 11)
- 7) Middlesex (Code: 12)
- 8) Monmouth (Code: 13)
- 9) Morris (Code: 14)
- 10) Passaic (Code: 16)
- 11) Union (Code: 20)

II. April 1st 1960 Census Industrial Female Employment

A) State and Aggregated Labor Market Areas

- 1) State (Code: 00)

- 2) Newark L. M. A. (Code: 29)
- 3) Paterson-Clifton-Passaic (Code: 30)

B) Major County Areas

- 1) Atlantic (Code: 01)
- 2) Bergen (Code: 02)
- 3) Camden (Code: 04)
- 4) Essex (Code: 07)
- 5) Hudson (Code: 09)
- 6) Mercer (Code: 11)
- 7) Middlesex (Code: 12)
- 8) Monmouth (Code: 13)
- 9) Morris (Code: 14)
- 10) Passaic (Code: 16)
- 11) Union (Code: 20)

III April 1st 1960 Census Industrial Employment - Total Both Sexes

A) Minor County Areas

- 1) Burlington (Code: 03)
- 2) Cape May (Code: 05)
- 3) Cumberland (Code: 06)
- 4) Gloucester (Code: 08)
- 5) Hunterdon (Code: 10)
- 6) Ocean (Code: 15)
- 7) Salem (Code: 17)

- 8) Somerset (Code: 18)
- 9) Sussex (Code: 19)
- 10) Warren (Code: 21)

IV April 1st 1960 Census Occupational Male Employment

A) State and Aggregated Labor Market Areas

- 1) State (Code: 00)
- 2) Newark L. M. A. (Code: 29)
- 3) Paterson-Clifton-Passaic L. M. A. (Code: 30)

B) Major County Areas

- 1) Atlantic (Code: 01)
- 2) Bergen (Code: 02)
- 3) Camden (Code: 04)
- 4) Essex (Code: 07)
- 5) Hudson (Code: 09)
- 6) Mercer (Code: 11)
- 7) Middlesex (Code: 12)
- 8) Monmouth (Code: 13)
- 9) Morris (Code: 14)
- 10) Passaic (Code: 16)
- 11) Union (Code: 20)

C) Minor County Areas

- 1) Burlington (Code: 03)
- 2) Cape May (Code: 05)

- 3) Cumberland (Code: 06)
- 4) Gloucester (Code: 08)
- 5) Hunterdon (Code: 10)
- 6) Ocean (Code: 15)
- 7) Salem (Code: 17)
- 8) Sussex (Code: 19)
- 9) Warren (Code: 21)

V April 1st 1960 Census Occupational Female Employment

A) State and Aggregated Labor Market Areas

- 1) State (Code: 00)
- 2) Newark L. M. A. (Code: 29)
- 3) Paterson-Clifton-Passaic L. M. A. (Code: 30)

B) Major County Areas

- 1) Atlantic (Code: 01)
- 2) Bergen (Code: 02)
- 3) Camden (Code: 04)
- 4) Essex (Code: 07)
- 5) Hudson (Code: 09)
- 6) Mercer (Code: 11)
- 7) Middlesex (Code: 12)
- 8) Monmouth (Code: 13)
- 9) Morris (Code: 14)
- 10) Passaic (Code: 16)
- 11) Union (Code: 21)

C) Minor County Areas

- 1) Burlington (Code: 03)
- 2) Cape May (Code: 05)
- 3) Cumberland (Code: 06)
- 4) Gloucester (Code: 08)
- 5) Hunterdon (Code: 10)
- 6) Ocean (Code: 15)
- 7) Salem (Code: 17)
- 8) Sussex (Code: 19)
- 9) Warren (Code: 21)

VI March 1960 CES (Current Employment Statistics) Industry Employment

A) State and Aggregated Labor Market Areas

- 1) State (Code: 00)
- 2) Camden L. M. A. (Code: 28)
- 3) Newark L. M. A. (Code: 29)
- 4) Paterson-Clifton-Passaic L. M. A. (Code: 30)
- 5) Perth Amboy-New Brunswick L. M. A. (Code: 31)

B) Major County Areas

- 1) Atlantic (Code: 01)
- 2) Hudson (Code: 09)
- 3) Mercer (Code: 11)
- 4) Monmouth (Code: 13)

C) Minor County Areas

- 1) Cape May (Code: 05)
- 2) Cumberland (Code: 06)
- 3) Hunterdon (Code: 10)
- 4) Ocean (Code: 15)
- 5) Salem (Code: 17)
- 6) Sussex (Code: 19)
- 7) Warren (Code: 21)

VII April 1960 CES Industry Employment

A) State and Aggregated Labor Market Areas

- 1) State (Code: 00)
- 2) Camden L. M. A. (Code: 28)
- 3) Newark L. M. A. (Code: 29)
- 4) Paterson-Clifton-Passaic (Code: 30)
- 5) Perth Amboy-New Brunswick (Code: 31)

B) Major County Areas

- 1) Atlantic (Code: 01)
- 2) Hudson (Code: 09)
- 3) Mercer (Code: 11)
- 4) Monmouth (Code: 13)

C) Minor County Areas

- 1) Cape May (Code: 05)
- 2) Cumberland (Code: 06)

- 3) Hunterdon (Code: 10)
- 4) Ocean (Code: 15)
- 5) Salem (Code: 17)
- 6) Sussex (Code: 19)
- 7) Warren (Code: 21)

VIII Annual Average 1960 CES Industry Employment

A) State and Aggregated Labor Market Areas

- 1) State (Code: 00)
- 2) Camden L. M. A. (Code: 28)
- 3) Newark L. M. A. (Code: 29)
- 4) Paterson-Clifton-Passaic L. M. A. (Code: 30)
- 5) Perth Amboy-New Brunswick (Code: 31)

B) Major County Areas

- 1) Atlantic (Code: 01)
- 2) Hudson (Code: 09)
- 3) Mercer (Code: 11)
- 4) Monmouth (Code: 13)

C) Minor County Areas

- 1) Cape May (Code: 05)
- 2) Cumberland (Code: 06)
- 3) Hunterdon (Code: 10)
- 4) Ocean (Code: 15)
- 5) Salem (Code: 17)

6) Sussex (Code: 19)

7) Warren (Code: 21)

IX Projected 1975 Annual Average CES Industry Employment

A) State and Aggregated Labor Market Areas

1) State (Code: 00)

2) Camden L. M. A. (Code: 28)

3) Newark L. M. A. (Code: 29)

4) Paterson-Clifton-Passaic L. M. A. (Code: 30)

5) Perth Amboy-New Brunswick L. M. A. (Code: 31)

B) Major County Areas

1) Atlantic (Code: 01)

2) Hudson (Code: 09)

3) Mercer (Code: 11)

4) Monmouth (Code: 13)

C) Minor County Areas

1) Cape May (Code: 05)

2) Cumberland (Code: 06)

3) Hunterdon (Code: 10)

4) Ocean (Code: 15)

5) Salem (Code: 17)

6) Sussex (Code: 19)

7) Warren (Code: 21)

X April 1st 1960 Census Employment Commutation Data

A) Industry Employment Commutation - Out

- 1) Atlantic County (Code: 01)
- 2) Bergen County (Code: 02)
- 3) Burlington County (Code: 03)
- 4) Camden County (Code: 04)
- 5) Cape May County (Code: 05)
- 6) Cumberland County (Code: 06)
- 7) Essex County (Code: 07)
- 8) Gloucester County (Code: 08)
- 9) Hudson County (Code: 09)
- 10) Hunterdon County (Code: 10)
- 11) Mercer County (Code: 11)
- 12) Middlesex County (Code: 12)
- 13) Monmouth County (Code: 13)
- 14) Morris County (Code: 14)
- 15) Ocean County (Code: 15)
- 16) Passaic County (Code: 16)
- 17) Salem County (Code: 17)
- 18) Somerset County (Code: 18)
- 19) Sussex County (Code: 19)
- 20) Union County (Code: 20)
- 21) Warren County (Code: 21)
- 22) Pennsylvania (Code: 23)

- 23) New York (Code: 24)
- 24) Delaware (Code: 25)
- 25) Elsewhere (Code: 26)

B) Occupational Employment Commutation - Out

- 1) Atlantic County (Code: 01)
- 2) Bergen County (Code: 02)
- 3) Burlington County (Code: 03)
- 4) Camden County (Code: 04)
- 5) Cape May County (Code: 05)
- 6) Cumberland County (Code: 06)
- 7) Essex County (Code: 07)
- 8) Gloucester County (Code: 08)
- 9) Hudson County (Code: 09)
- 10) Hunterdon County (Code: 10)
- 11) Mercer County (Code: 11)
- 12) Middlesex County (Code: 12)
- 13) Monmouth County (Code: 13)
- 14) Morris County (Code: 14)
- 15) Ocean County (Code: 15)
- 16) Passaic County (Code: 16)
- 17) Salem County (Code: 17)
- 18) Somerset County (Code: 18)
- 19) Sussex County (Code: 19)
- 20) Union County (Code: 20)
- 21) Warren County (Code: 21)

- 22) Pennsylvania (Code: 23)
- 23) New York (Code: 24)
- 24) Delaware (Code: 25)
- 25) Elsewhere (Code: 26)

XI April 1st 1960 Census Employment Commutation Control Figures

- A) Industry Employment Figures - after adjustment for net in-out commutation
 - 1) Aggregated Labor Market Areas
 - a) Newark L. M. A. (Code: 29)
 - b) Paterson-Clifton-Passaic L. M. A. (Code: 30)
 - 2) Major County Areas
 - a) Hudson (Code: 09)
 - b) Mercer (Code: 11)
 - 3) Residual State Area (Code: 33)
- B) Occupational Employment Figures - after adjustment for net in-out commutation
 - 1) Aggregated Labor Market Areas
 - a) Newark L. M. A. (Code: 29)
 - b) Paterson-Clifton-Passaic L. M. A. (Code: 30)
 - 2) Major County Areas
 - a) Hudson (Code: 09)
 - b) Mercer (Code: 11)

3) Residual State Area (Code: 33)

XII National Ratios of Wage and Salary (W. & S.) Employment To

Total Employment (T. E.) - by Industry

- A) 1960 ratios - by industry
- B) 1975 projected ratios - by industry

XIII Covered Industrial Employment Ratios

A) 1960 Ratios

1) Major County Areas

- a) Bergen (Code: 02)
- b) Camden (Code: 04)
- c) Essex (Code: 07)
- d) Middlesex (Code: 12)
- e) Morris (Code: 14)
- f) Passaic (Code: 16)
- g) Union (Code: 20)

2) Minor County Areas

- a) Burlington (Code: 03)
- b) Gloucester (Code: 08)
- c) Somerset (Code: 18)

B) 1975 Projected Ratios

1) Major County Areas

- a) Bergen (Code: 02)
- b) Camden (Code: 04)
- c) Essex (Code: 07)
- d) Middlesex (Code: 12)
- e) Morris (Code: 14)
- f) Passaic (Code: 16)
- g) Union (Code: 20)

2) Minor County Areas

- a) Burlington (Code: 03)
- b) Gloucester (Code: 08)
- c) Somerset (Code: 18)

XIV Estimated New Jersey 1960 Occupational Death and Retirement Rates

XV Data Codes and Classification Systems

A) Major Standard Industry Code Structures

- 1) Level II
- 2) Level III
- 3) Level III A
- 4) Level IV
- 5) Level V

B) Special Industry Code Structures

- 1) Level II S
- 2) Level III S
- 3) Level IV S
- 4) Level V S

C) Standard Geographical Code Structures

- 1) Level II G
- 2) Level III G
- 3) Level IV G

D) Major Standard Occupational Code Structures

- 1) Level I O
- 2) Level III O
- 3) Level IV O

E) Special Occupational Code Structures

- 1) Level II OS
- 2) Level III OS
- 3) Level IV OS
- 4) Level V OS
- 5) Level VI OS

F) Special Code Additions

XVI National B. L. S. Industrial-Occupational Matrix Tape

APPENDIX F3: STANDARD AND SPECIAL

INDUSTRY CODE STRUCTURES

APPENDIX F3

AREA CODE STRUCTURES:

ITEM: XV C) "STANDARD GEOGRAPHICAL CODE STRUCTURES"

LEVEL II G	LEVEL III G	LEVEL IV G	LEVEL V G
09	09	09	09
11	11	11	11
29	29		
		07	07
		14	14
		20	20
30	30		
		02	02
		16	16
33			
	28		
		03	03
		04	04
		08	08
	31		
		12	12
		18	18
	05	05	05
	06	06	06
	10	10	10
	15	15	15
	17	17	17
	19	19	19
	21	21	21
			01
			13
	01	01	23
	13	13	24
			25
			26

SPECIAL CODE ADDITIONS ITEM: (XV F)

Add to: 6999 Operatives

- 6330 Inspectors, Metalworking, B
- 6340 Machine Tool Operators, B
- 6350 Electroplaters
- 6360 Electroplater Helpers

Add to: 6310 Assemblers, Metalworking, Class A

- 6320 Assemblers, Metalworking,
Class B

Add to: 3910 Accounting Clerks

- 3920 Bookkeepers, Hand

Add to: 1640 Radio Operators

- 1630 Air Traffic Controllers

APPENDIX F4: CODE STRUCTURE DIMENSIONS

Attribute	Level	No. of Codes
Industry	I	1
	II	9
	III	12 (6 Common to II)
	III A	28 (8 Common to II)
	IV	66 (2 Common to III)
	V	117 (40 Common to IV)
	Total	155
Occupation	I	1
	II	10
	III	36 (3 Common to II)
	IV	158 (3 Common to Both) (14 Common to III)
	Total	191
Area	I	1
	II	5
	III	15 (4 Common to II)
	IV	21 (11 Common to III)
	V	25 (20 Common to IV)
	Total	